



**sormani**





# INDICE

INDEX

4	CHARME
16	INFINITY
30	VANITY
60	VANITY GOLD
70	CRISTAL
86	TOBAGO
102	HERNEST
120	NOIR
136	MOVE
154	ISLAND
170	TIP WING
188	RULING
202	SABOT
214	POPPY NEW
224	MITO
236	QUITE
242	THEA
246	SNAIL
250	GOGO
254	BADOS
256	MALINDI
260	STILL
262	SER
264	OPIE
270	PRINCE
274	FACILE 1
276	FACILE 2
278	MIDI'
280	PETIT

# CHARME

CHARM, IL DIVANO CHE RACCHIUDE FASCINO, CATTURA SUBITO L'ATTENZIONE E SEDUCE CON TUTTI I SUOI PARTICOLARI.  
UNICO NEL SUO GENERE CON LA FORMA ARROTONDATA E BRACCIOLI CURVI, NASCE PER ESSERE IL PROTAGONISTA DEL SALOTTO,  
ADATTO PER LO STILE MODERNO MA ANCHE CLASSICO.

CHARM SOFA ENCLOSING GLAMOR, CATCHES ATTENTION AND SEDUCES WITH ALL ITS DETAILS.  
IT'S UNIQUE WITH ROUNDED SHAPE AND CURVED ARMRESTS, IT WAS CREATED TO BE THE STAR OF THE LIVING ROOM,  
SUITABLE FOR MODERN AND CLASSIC STYLE..



CHARME













# INFINITY

INFINITY È UN DIVANO PROTAGONISTA.

LA BASE, LA DOPPIA PANCA, I PROFILI, LE CUSCINATURE... OGNI DETTAGLIO CONCORRE A FORMARE UN DIVANO DI CLASSE E INDIMENTICABILE. IDEATO PER ABITARE SPAZI NOBILI, E PER PRENDERE IMPORTANTE L'AMBIENTE, QUESTO MODELLO ABBINA L'ALTA QUALITÀ DEI MATERIALI A UN DESIGN SUPERIORE. INFINITY RISPESCHIA L'ECCELLENZA DEL MADE IN ITALY.

INFINITY IS A PROTAGONIST.

THE BASE, THE DOUBLE BENCH, THE PIPINGS, THE CUSHIONS,... EVERY SINGLE DETAIL CONTRIBUTE TO CREATE AN HIGH-CLASS UNFORGETTABLE SOFA. CONCEIVED TO LIVE IN NOBLE SPACES, TO GIVE IMPORTANCE TO THE LIVING ROOM, THIS MODEL MIX TOGETHER THE HIGH QUALITY OF MATERIALS AND A SUPERIOR DESIGN. INFINITY REFLECTS THE MADE IN ITALY EXCELLENCE.

INFINITY играет главную роль в интерьере.

Основа, двойная скамья, профиль, подушки .... каждая деталь создаёт диван стильным и незабываемым.

INFINITY предназначен для люксовых помещений, придаёт им важное значение, благодаря высокому качеству материалов и превосходному дизайну.

INFINITY отражает всё превосходство Made in Italy.



INFINITY









## INFINITY

LA DOPPIA PANCA, UNO DELLE CARATTERISTICHE CHIAVE DI QUESTO MODELLO, PERMETTE DI ABITARE A PIENO GLI SPAZI, USCENDO DAGLI SCHEMI E ALLARGANDO GLI ORIZZONTI. LA BASE A X CROMATA CONFERISCE CARATTERE AL DIVANO, CHE È ALTAMENTE PERSONALIZZABILE. SI PUÒ GIOCARE CON I PROFILI, NON SOLO PER I COLORI MA ANCHE PER I MATERIALI; INFINITY RAGGIUNGE INFATTI IL MASSIMO DELLA SUA NOBILTÀ GRAZIE ALL'ACCOSTAMENTO TONO SU TONO DI TESSUTO E PELLE.

THE DOUBLE BENCH, ONE OF THE DISTINCTIVE TRAITS OF THIS MODEL, ALLOWS US TO LIVE DEEPLY THE SPACES, GOING OUT THE FRAMES OF THE MIND AND BROADENING OUR HORIZONS. THE CHROMED X BASE GIVES CHARACTER TO THE SOFA, WHICH IS HIGHLY CUSTOMIZABLE. YOU CAN PLAY WITH THE WIDE PIPING, NOT ONLY WITH COLORS BUT ALSO WITH MATERIALS; INFINITY REACHES THE TOP OF HIS ARISTOCRACY THANKS TO THE MATCH, TONE ON TONE, OF FABRIC AND LEATHER.

Двойная скамья- это одна из ключевых характеристик этой модели, которая позволяет использовать полноту пространства, выходя за схемы и расширяя горизонты.

Благодаря хромированной основе X дивану можно придать персональный характер, не только в выборе цветов, но и материалов.

INFINITY- это максимальный люкс, благодаря подбору тонов цвета ткани и кожи.



# INFINITY

INFINITY: SENZA FINE, COME LE POSSIBILITÀ DI CREARE LA PROPRIA COMPOSIZIONE. CON INFINITY SI DEVE OSARE, ANDANDO OLTRE IL SEMPLICE DIVANO LINEARE, CREANDO COMPOSIZIONI CON ELEMENTI ANGOLARI, DOPPIA PANCA E CHAISE LONGUE. INFINITY HA ANCHE UNA POLTRONA BERGÈRE, ELEGANTE, NOBILE, IMPORTANTE E DI CARATTERE, PROPRIO COME TUTTA LA COLLEZIONE.

INFINITY: ENDLESS, AS THE POSSIBILITIES TO CREATE YOUR OWN COMPOSITION. WITH INFINITY YOU MUST VENTURE, GOING OVER THE SIMPLE LINEAR SOFA, CREATING COMPOSITIONS WITH CORNER ELEMENTS, DOUBLE BENCH AND CHAISE LONGUE. INFINITY HAS GOT A BERGÈRE ARMCHAIR TOO, ELEGANT, NOBLE, IMPORTANT AND WITH CHARACTER, JUST LIKE THE WHOLE COLLECTION.

INFINITY означает БЕЗГРАНИЧНЫЙ, так же как и возможности создания собственной композиции. С INFINITY у Вас есть возможность выйти за пределы простого линейного дивана, создавая композиции с угловыми элементами, двойным сидением и шезлонгом. INFINITY имеет так же кресло Berg элегантное, стильное, комфортное, с характером ... как и вся коллекция.

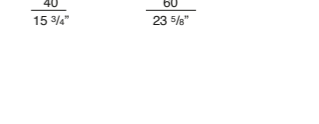
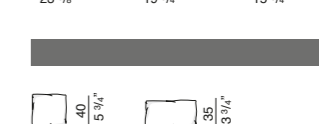
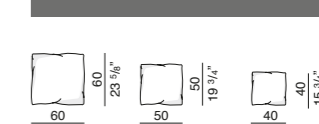
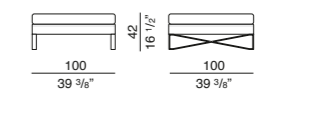
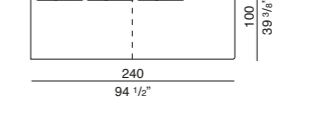
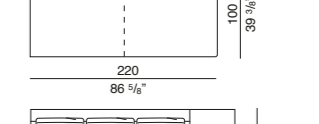
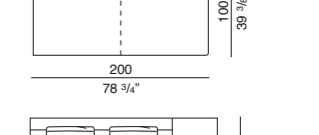
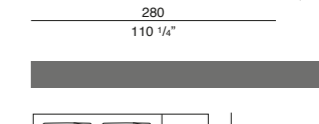
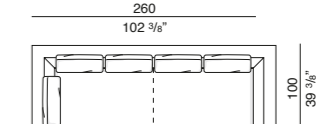
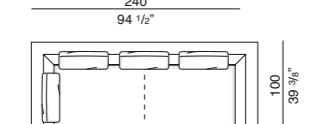
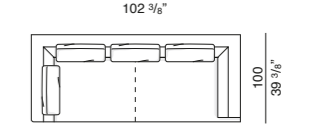
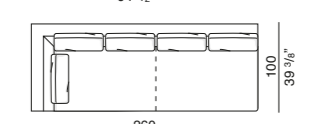
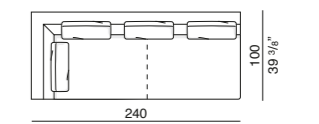
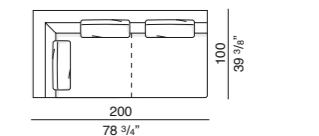
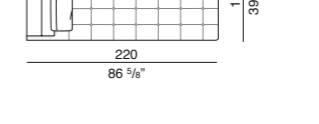
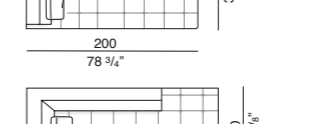
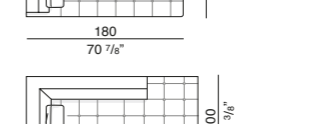
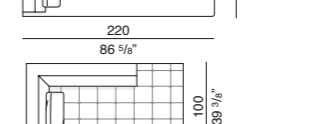
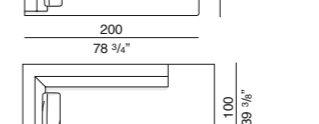
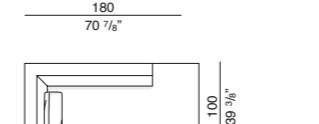
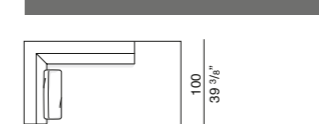
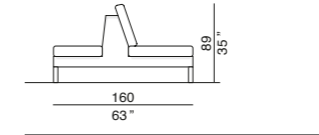
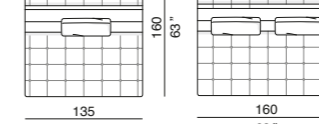
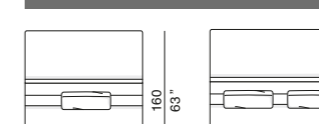
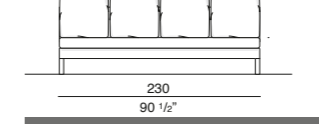
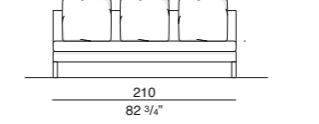
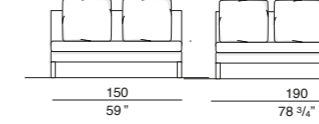
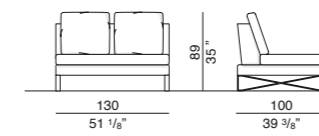
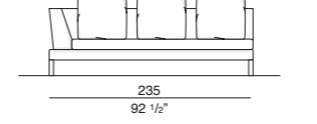
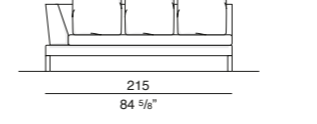
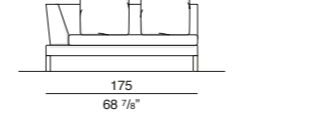
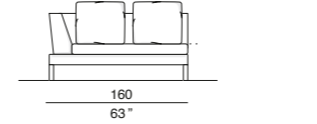
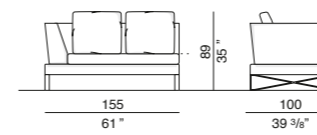
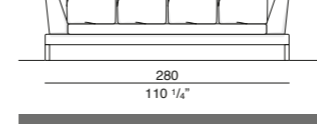
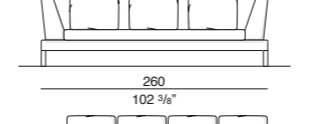
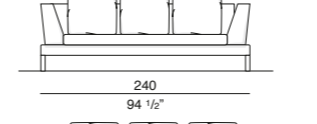
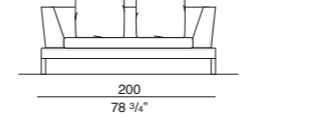
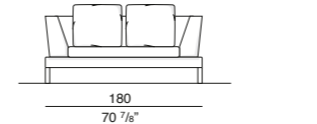
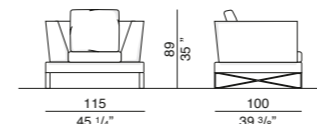
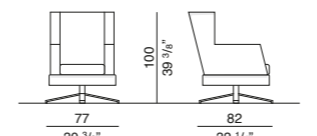



# VANITY

VANITY HA UN NOME CHE È UN EVIDENTE RICHIAMO ALLA SUA RAFFINATA ELEGANZA. È UN DIVANO DAL LUSO DISCRETO ED INTIMISTICO. ABBINA LA RICCHEZZA E IL CALORE DEL PREZIOSO RIVESTIMENTO CON LA PULIZIA FORMALE DEL BASAMENTO DALLA LINEA SOBRIA ED ELEGANTE.

IL MODELLO VANITY È E ECLETTICO: PUÒ PASSARE DALLA ELEGANTE SOBRIETÀ AD UNO STILE CLASSICO E PREZIOSO, TUTTO DIPENDE DALLA SCELTA CROMATICA DEI RIVESTIMENTI E DELLA BASE.

VANITY HAS A NAME THAT IS A CLEAR REFERENCE TO ITS FINE ELEGANCE, IS A SOFA WITH A DISCREET AND INTIMATE LUXURY. IT COMBINES THE WEALTH AND THE WARMTH OF THE PRECIOUS COVERING WITH THE CLEAN LINES OF THE BASE, WHICH HAS A SOBER AND ELEGANT LINE.

VANITY IS ECLECTIC: IT CAN CHANGE FROM THE ELEGANT SIMPLICITY TO A CLASSIC AND PRECIOUS STYLE. EVERYTHING DEPENDS ON THE CHOICE OF COLORS OF THE COVERING AND OF THE BASEMENT.

Vanity, чье имя полностью раскрывает и подчёркивает его элегантность, - это диван с ненавязчивой и тонкой роскошью. Он сочетает в себе богатство и тепло благородной ткани и чистоту линий основания, с его простым и элегантным контуром. Vanity является эклектической моделью: она может видоизменяться от элегантной простоты до классического и люксового стиля. Всё зависит от выбора цветов чехла и основания.



VANITY







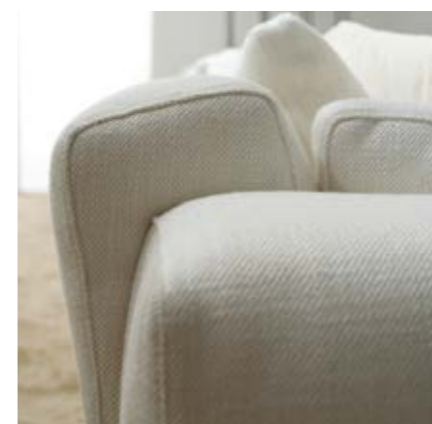

## VANITY

LA LINEA, LE DIMENSIONI IMPORTANTI, LA SEDUTA CONFORTEVOLE BASSA E PROFONDA, LE AMPIE CUSCINATURE DI GRANDE EFFETTO CHE GARANTISCONO UN COMFORT COMPLETO, SONO SIMBOLO DI EQUILIBRIO TRA SEMPLICITÀ ED ELEGANZA, LE QUALI SONO GARANTITE DALLA LAVORAZIONE DI TIPO TRADIZIONALE CHE AFFIDA OGNI FASE ALL'ESPERIENZA DEI PROPRI ARTIGIANI.

THE LINE THE IMPORTANT DIMENSIONS, THE LOW AND DEEP SEAT AND THE IMPRESSIVE LARGE CUSHIONS THAT ENSURE A TOTAL COMFORT, ARE SYMBOL OF BALANCE BETWEEN SIMPLICITY AND ELEGANCE, WHICH ARE GUARANTEED BY THE TRADITIONAL MANUFACTURING THAT RELIES ON THE EXPERIENCE OF OUR CRAFTSMEN.

Линия, важные размеры, низкое глубокое сиденье и внушительные широкие подушки, обеспечивающие полноту комфорта, символизируют баланс простоты и элегантности, гарантированных традициями производства и опытом мастеров.ей – главный принцип, которым мы руководствовались, создавая Vanity.









# VANITY

VANITY È POLTRONA, DIVANI, COMPOSIZIONI LINEARI, ANGOLARI E IN PARTICOLARE CON ELEMENTI TERMINALI A CHAISE LONGUE, A PENISOLA CHE TROVANO FACILMENTE SPAZIO NELL'AMBIENTE CHE LO OSPITA.

VANITY IS AN ARMCHAIR, A SOFA, ITS LINEAR AND CORNER COMPOSITION, IS DEVELOPED WITH THESE PARTICULAR ELEMENTS WITH CHAISE LONGUE. PENINSULA-STYLE COMPOSITIONS CAN BE BEAUTIFULLY ARRANGED IN THE CORNER OF A ROOM.

Кресло, большой или маленький диван, линейная или угловая композиция, диван с шезлонгом или с модулем «полуостровом» - Vanity легко впишется в любое пространство.

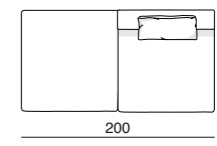
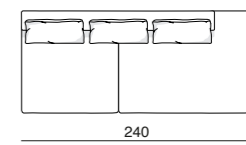
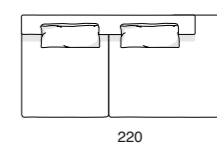
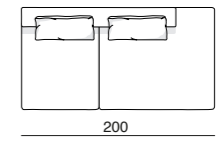
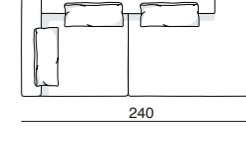
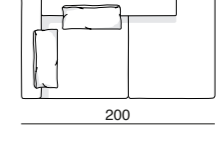
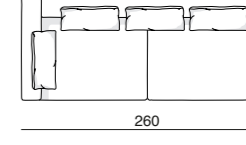
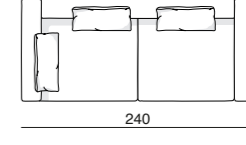
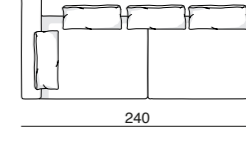
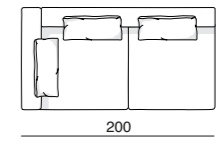
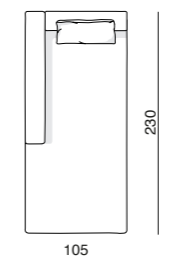
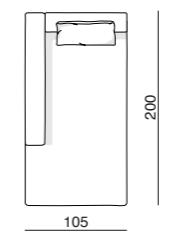
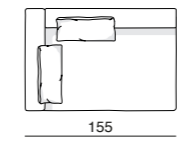
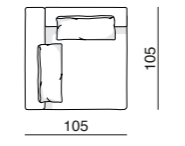
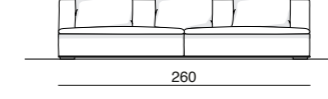
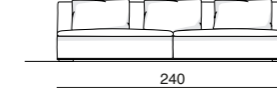
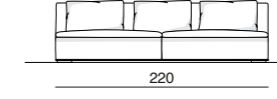
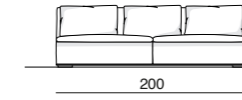
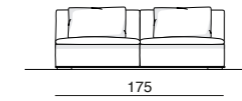
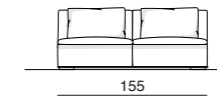
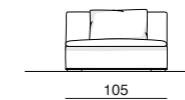
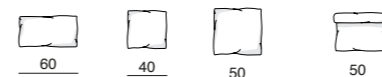
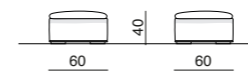
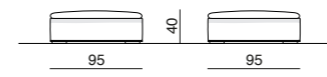
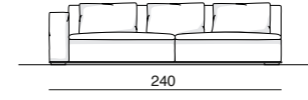
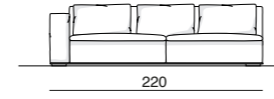
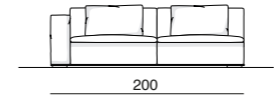
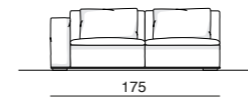
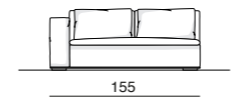
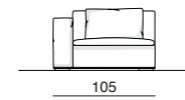
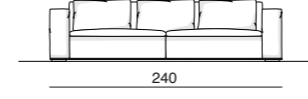
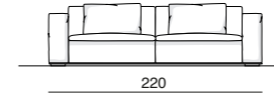
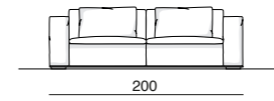
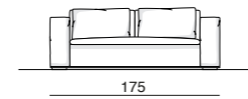
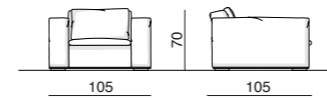

## VANITY

HA UNA FORMA MORBIDA E ARROTONDATA CHE MOSTRA LA SUA NATURA ACCOGLIENTE; INOLTRE LE VARIE POSSIBILI PERSONALIZZAZIONI CON PROFILI E CORDONETTI EVIDENZIANO LA NATURALE ELEGANZA DI QUESTO MODELLO.

IT HAS A SOFT AND ROUNDED SHAPE THAT SHOWS ITS WELCOMING NATURE; MOREOVER, THE DIFFERENT POSSIBILITIES OF CUSTOMIZATION (E.G. WITH CORDONETS) OUTLINE THE NATURAL ELEGANCE OF THIS MODEL.

Модель имеет мягкие и скруглённые формы, что подчёркивает её природную открытость; более того, различные возможности персонализации (например, шнуром или цветом профиля в основании) выделяют присущую модели элегантность.











## VANITY GOLD

DALLE LINE ELEGANTI DEL VANITY NASCE VANITY GOLD, UN PEZZO MAESTOSO CHE SFOGGIA UNA IMPUNTURA IMPORTANTE SOLO SU SCHIENALE E BRACCIOLI, RIMANENDO COSÌ RAFFINATO E CONFORTEVOLE GRAZIE ALLA SEDUTA BASSA E PROFONDA.

FROM THE ELEGANT LINES OF THE VANITY, VANITY GOLD IS A MAJESTIC PIECE THAT SHOWS AN IMPORTANT STITCHING ONLY ON THE BACKREST AND ARMREST, REMAINING SOPHISTICATED AND COMFORTABLE THANKS TO THE LOW AND DEEP SEAT.











# VANITY GOLD

LAVORO DI ALTA ARTIGIANALITÀ VANITY GOLD E POLTRONA HANNO UNO STILE UNICO ED INCONFONDIBILE CHE CONFERISCE ELEGANZA ALL'AMBIENTE IN CUI È INSERITO.

WORK OF HIGHT CRAFTSMANSHIP, VANITY GOLD AND ARMCHAIR HAVE A UNIQUE STYLE THAT GIVES ELEGANCE TO THE ENVIRONMENT IN WHICH IT IS LOCATED.

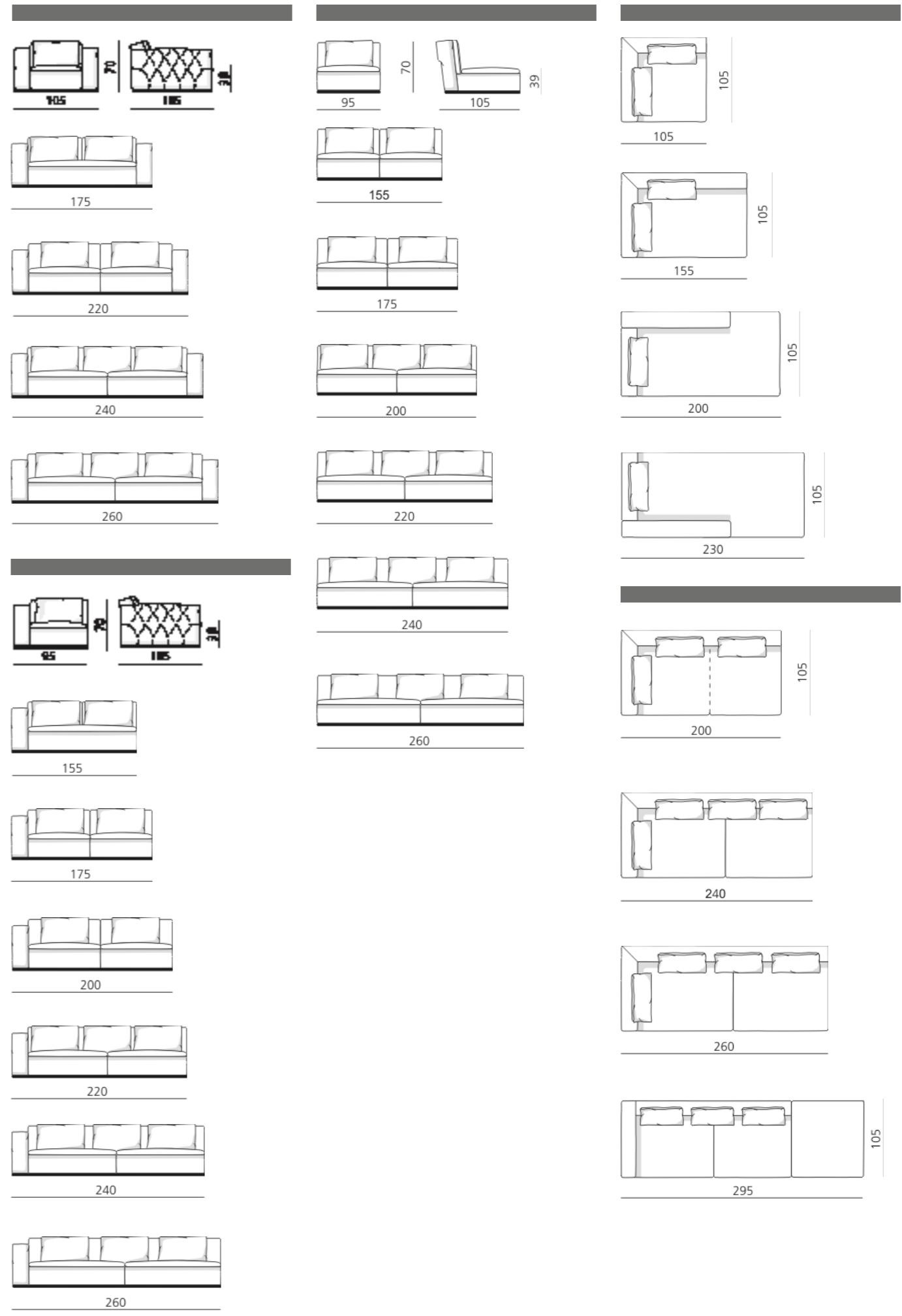

# CRISTAL

LINEE PULITE ED ESSENZIALI REALIZZATE CON GARBO E RIGORE. CRYSTAL, NATO DA APPROFONDITE RICERCHE E SINERGIE, HA QUINDI UNA FORTE VALENZA ESPRESSIVA E UN CARATTERE DECISAMENTE ATTUALE.

WITH ITS CLEAN AND ESSENTIAL LINES MADE WITH GRACE AND STRICTNESS AND BORN FROM LOTS OF RESEARCHES AND SYNERGIES, THE MODEL CRYSTAL HAS A STRONG EXPRESSIVE VALUE AND A DEFINITELY CURRENT CHARACTER.

При помощи простых и базовых линий модель выполнена с грацией и строгостью, рождена в поиске и синергии. Crystal силён экспрессией формы и имеет определённо современный характер.





## CRISTAL

ESATTO MIX TRA PROPORZIONE ED EQUILIBRIO, È UN ELEMENTO DI FORTE IMPATTO SCENOGRAFICO IN GRADO DI CARATTERIZZARE L'AMBIENTE IN MANIERA DECISA.  
IL DETTAGLIO DEI PIEDINI, IN ARMONICO CONTRASTO CON L'INSIEME DEL DIVANO, INTERROMPE LA LINEARITÀ DELLE FORME.

CRYSTAL IS A PERFECT MIX BETWEEN PROPORTION AND EQUILIBRIUM, IS AN ELEMENT OF STRONG VISUAL IMPACT ABLE TO CHARACTERIZE THE ENVIRONMENT IN A DECISIVE WAY.  
THE DETAIL OF THE FEET, WHICH CONTRASTS HARMONIOUSLY WITH THE WHOLE SOFA, INTERRUPTS THE LINEARITY OF THE SHAPES.

Crystal являя собой превосходное сочетание пропорций и равновесия, этот диван имеет сильный зрительный эффект, способный характеризовать помещение определённым образом. Особенные ножки, гармонично контрастирующие с самим диваном, визуалью прерывают линейность форм.





L'ELEGANZA È SOTTOLINEATA DALLA SEMPLICITÀ DEL DESIGN DEL MODELLO, CARATTERIZZATO DALLA PREZIOSITÀ DELLA TRAPUNTATURA DEL BRACCIOLO CHE METTE IN RISALTO L'ATTENZIONE PER I DETTAGLI SARTORIALI.

THE ELEGANCE IS OUTLINED BY THE SIMPLICITY OF THE DESIGN OF THE MODEL, CHARACTERIZED BY THE PRECIOUSNESS OF THE ARMREST QUILTING, THAT EMPHASIZES THE ATTENTION TO TAILORING DETAILS.

Элегантность, подчеркнутая простотой дизайна модели, характеризуется богатством отделки подлокотника, что привлекает внимание к деталям кроя.











ESSO, COMPLETO DI ANTISCIVOLO, È IN ACCIAIO CROMATO REALIZZATO SU PROGETTO ESCLUSIVO E CONFERISCE UNA LINEA DEL TUTTO PARTICOLARE AL DIVANO RENDENDO STABILE CIÒ CHE ALL'APPARENZA È INCERTO, CONFERENDO ALL'INSIEME UNA LIMPIDEZZA FORMALE.

THE FEET, IN CHROME STEEL COMPREHENSIVE OF NON -SLIP SYSTEM, ARE CARRIED OUT ON AN EXCLUSIVE DESIGN AND GIVE THE SOFA A VERY SPECIAL LINE, MAKING STABLE WHAT SEEMINGLY IS UNCERTAIN, GIVING THE WHOLE A FORMAL CLARITY.

Ножки в хромированной стали со специальной системой против скольжения имеют свой эксклюзивный дизайн, с ними диван приобретает свой особенный стиль. Они словно делают стабильным кажущееся шатким, придавая облику дивана степенную чёткость.



# TOBAGO

DALLA NOSTRA PASSIONE PER LE LINEE SEMPLICI E CONTEMPORANEE, ABBIAMO CREATO UN MODELLO SEMPRE ATTUALE.  
COME IL CLASSICO DIVANO DI FAMIGLIA, TOBAGO DA ATMOSFERA ALL'AMBIENTE, CON QUEL TOCCO DI DESIGN CONTEMPORANEO CHE LO  
RENDE UNICO.

FROM OUR PASSION FOR SIMPLE AND CONTEMPORARY LINES, WE HAVE CREATED AN ALWAYS UP-TO-DATE MODEL.  
AS THE CLASSIC FAMILY SOFA, TOBAGO GIVES A SPECIAL ATMOSPHERE TO THE LIVING ROOM, TOGETHER WITH A TOUCH OF  
CONTEMPORARY DESIGN, THAT MAKE THIS SOFA UNIQUE.

Эту простую, но всегда актуальную модель, задуманную как классический семейный диван, мы создали, вдохновившись чёткими  
линиями современного дизайна. Будучи его безупречным воплощением, Tobago придаёт повседневности особенный оттенок.





TOBAGO









## TOBAGO

TOBAGO NASCE CON BASAMENTO MOLTO ALTO PER ALLEGGERIRE L'AMBIENTE, NON APPESANTISCE LA ZONA CONVERSAZIONE. CON I CUSCINI MORBIDOSI USO BRACCIOLO CI SI PUÒ DISTENDERE E AVVOLGERSI COMPLETAMENTE PER IL RELAX ASSOLUTO.

TOBAGO IS BORN WITH A VERY LOW BASE TO LIGHTEN THE ENVIRONMENT, SO AS NOT TO OVERBURDEN THE CONVERSATION AREA. WITH THE USE OF THE ARMREST CUSHION YOU CAN STRETCH OUT AND COMPLETELY WRAP.

Благодаря низкому основанию, Tobago освобождает часть пространства, что создаёт лёгкую атмосферу в зоне отдыха. Мягкие подушки, удобные подлокотники – вот всё, что нужно для того, чтобы полностью расслабиться, блаженно растянувшись на диване.







# TOBAGO

TOBAGO È IN GRADO DI PADRONEGGIARE L'AMBIENTE.  
È DISPONIBILE COME POLTRONA, DIVANO, COMPOSIZIONE AD ANGOLO O CON CHAISE LONGUE, E DIVANO CON POUF.

TOBAGO IS ABLE TO RULE THE LIVING ROOM.  
IT IS AVAILABLE AS ARMCHAIR, SOFA, SOFA-COMPOSITION WITH CORNER OR CHAISE LONGUE, AND SOFA WITH POUF. THE COVER IS COMPLETELY REMOVABLE.

Тобаго может выполняться в виде кресла, маленького диванчика или большого дивана, задающего тон интерьеру, углового дивана, дивана с шезлонгом или пуфом.  
Все чехлы полностью съёмные и при желании могут меняться.

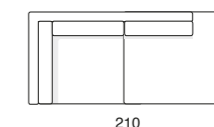
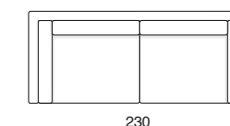
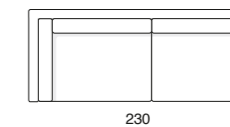
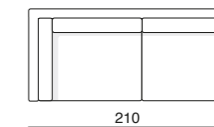
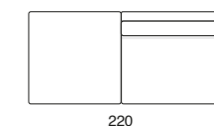
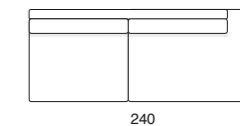
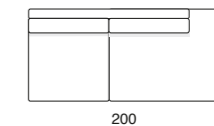
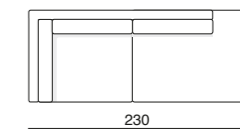
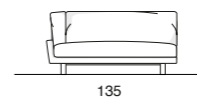
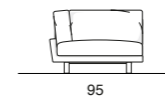
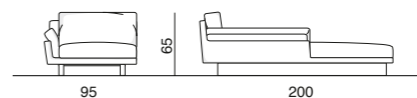
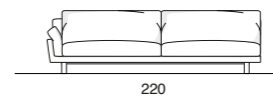
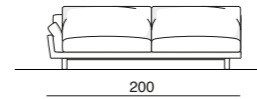
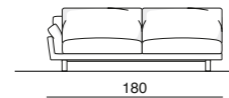
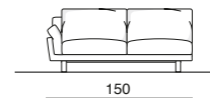
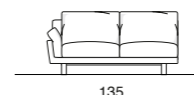
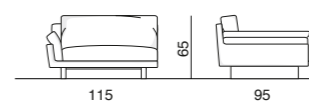
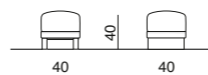
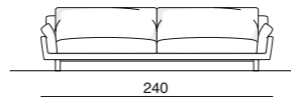
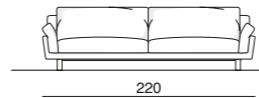
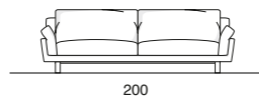
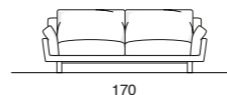
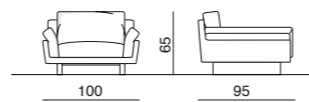

# HERNEST

HERNEST NASCE PER LA CLIENTELA ABITUATA A VIVERE A PIENO LA ZONA GIORNO.  
CREA MOVIMENTO CON COMPOSIZIONI PARTICOLARI E SOFISTICATE E DONA CARATTERE ALLE NOSTRE SERATE SUL DIVANO.

HERNEST WAS BORN FOR THE CLIENTELE USED TO LIVE DEEPLY THE LIVING ROOM.  
IT CREATES MOVEMENT WITH PARTICULAR AND SOPHISTICATED COMPOSITIONS, AND IT GIVES CHARACTER TO OUR EVENINGS SPENT ON THE SOFA.

Оригинальный угловой диван для тех, кто привык к неординарности.  
Необычные формы HerneSt придают динамичность окружающему пространству, что вносит особые нотки в непринуждённую вечернюю беседу.



HERNEST









## HERNEST

L'ELEGANTE FORMA GEOMETRICA CHE SCONVOLGE IL DIVANO, VIENE VALORIZZATA DALLA CUCITURA CON UN CORDONETTO CHE DELINEA CON CURA L'ORIGINALITÀ DI QUESTO DIVANO. LA VERSIONE IN PELLE VIENE DELINEATA DA UNA CUCITURA LARGA, SENZA CORDONETTO. QUESTO MODELLO NASCE NELLA DOPPIA VERSIONE DEI CUSCINI SCHIENALE, SI POSSONO REALIZZARE UNITI OPPURE DISTACCATI.

THE ELEGANT GEOMETRIC SHAPE THAT UPSETS THE SOFA IS ENHANCED BY STITCHING WITH A CORDONET CAREFULLY OUTLINING THE ORIGINALITY OF THIS SOFA. THE LEATHER VERSION IS DELINEATED BY A LARGE SEAM WITHOUT CORDONET. THIS MODEL COMES IN TWO VERSIONS OF THE BACKREST CUSHION, WHICH CAN BE MADE AS ONE OR DETACHED.

Элегантная ломаная форма дополнена подушками с окантовкой, которая подчёркивают оригинальность этого дивана.  
Модели в коже выполняются без окантовки.  
Двойной ряд спинных подушек, которые могут быть закреплёнными или свободными.







# HERNEST

HERNEST, INFINITE SOLUZIONI DI SEDUTA, POLTRONA, DIVANI, COMPOSIZIONI ANGOLARI, COMPOSIZIONI CHAISE LONGUE E UNA GAMMA NOTEVOLE DI ELEMENTI INCLINATI E AGGETTANTI. CON HERNEST SI POSSONO CREARE DIVANI LINEARI O COMPOSIZIONI SENZA BRACCIOLO SFRUTTANDO GLI ELEMENTI CON MENSOLE LACCATE O IN LEGNO.

HERNEST HAS INFINITE SOLUTIONS FOR SITTING, ARMCHAIR, SOFA, ANGULAR COMPOSITION, CHAISE LONGUE AND A CONSIDERABLE RANGE OF ELEMENTS RECLINING OR JUTTING. WITH HERNEST SOFA CAN BE CREATED LINEAR SOFAS OR COMPOSITIONS WITHOUT ARMREST BUT USING ELEMENT WITH LACQUERED OR WOOD SHELVES.

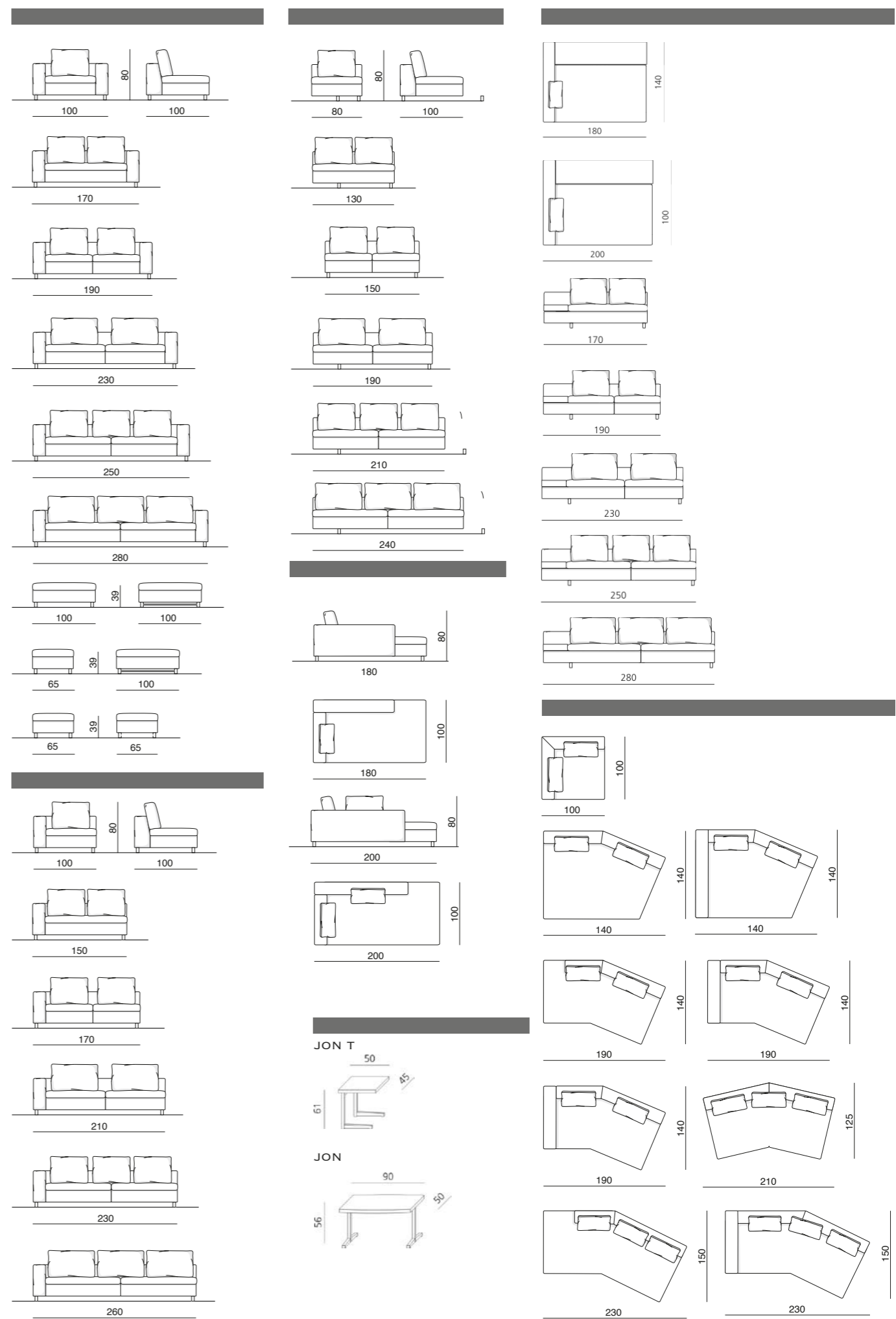

NOIR

CI PIACE INVENTARE ACCOSTARE NUOVE FORME DI DESIGN SEMPRE CON L'ASSOLUTA ELEGANZA CHE LEGANO NELL'ABITARE PIACERI SINCERI ALLE SEMPLICI FUNZIONALITÀ.  
NOIR ATMOSPHERA ESTREMAMENTE ESSENZIALE NEL VIVERE E NEL DISTENDERSI.

WE LIKE TO INVENT, NEW WAY OF APPROACHING DESIGN ALWAYS WITH ABSOLUTE ELEGANCE THAT BIND LIVING PLEASURE SIMPLE FUNCTIONALITY.  
NOIR ATMOSPHERE IS EXTREMELY ESSENTIAL IN LIVING AND RELXING.

Нам нравится создавать новые формы, сочетая безупречную элегантность с удобством и функциональностью.  
Noir дарит будням и праздникам атмосферу исключительной лёгкости.



NOIR











## NOIR

NOIR LO SI VEDE NEL DETTAGLIO DELLE CUCITURE CURATE CHE DELINEANO OGNI FORMA DEL MODELLO. NEL DETTAGLIO LO SI VEDE NELLA VERSIONE CON IL BRACCIOLO A SCIVOLO NELLA VERSIONE COMPONIBILE, MENTRE NELLA VERSIONE DIVANO LO SI PUÒ AVERE ANCHE NELLA VERSIONE CON IL BRACCIOLO UGUALE ALLO SCHIENALE.

NOIR SEES DETAILS OF THE PAINSTAKING STITCHING OUTLINING ALL THE FORMS OF THE MODEL. YOU CAN SEE THE DETAIL IN THE INCLINED ARMREST AND MODULAR VERSION, WHEREAS IN THE SOFA YOU CAN HAVE THE SAME A VERSION AS THE ARMREST AND BACKREST.

Noir притягивает внимание особой окантовкой, которая подчёркивает элегантные формы модели. Подлокотники и спинка могут быть наклонными.



# NOIR

NOIR NASCE PER AVERE LO SVILUPPO DELLE COMPOSIZIONI CON CHAISE LONGUE, LE PIÙ AMBITE, COMPOSIZIONI ANGOLARI E NELLE VERSIONI DIVANI E NELLA VERSIONE TRADIZIONALE ACCOMPAGNATO DALLA POLTRONA.

STUDIATO IN UNA VASTA GAMMA DI MISURE PER ACCONTENTARE OGNI SINGOLA ESIGENZA. RIVESTIMENTI COMPLETAMENTE SFODERABILI E INTERCAMPBIALI.

NOIR WAS CREATED FOR THE DEVELOPMENT OF THE COMPOSITION WITH A CHAISE LONGUE, THE MOST COVETED, ANGULAR COMPOSITIONS AND SOFA VERSION ACCOMPANIED BY THE CONVENTIONAL CHAIR.

STUDIED IN A WIDE RANGE OF SIZES TO SUIT EVERYONE'S NEEDS. THE COVER IS COMPLETELY REMOVABLE AND INTERCHANGEABLE.

Noir - это развитие принципа разнообразия в рамках одной модели: диваны с шезлонгом (наиболее популярный вариант), угловые диваны, небольшие диванчики, классические композиции, состоящие из большого дивана с креслом.

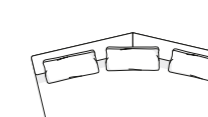
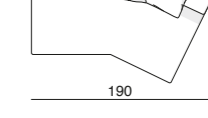
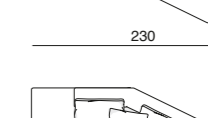
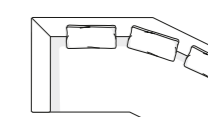
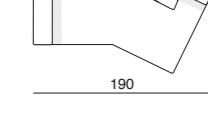
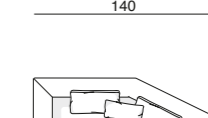
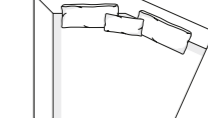
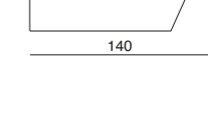
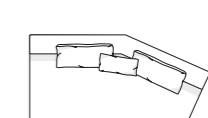
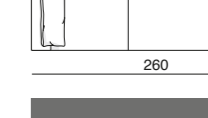
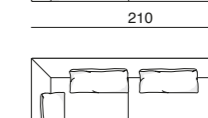
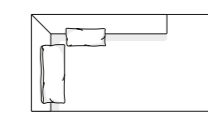
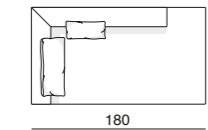
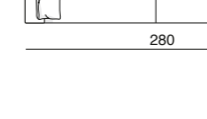
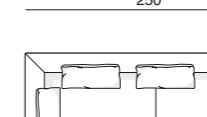
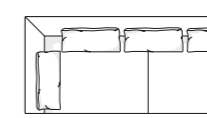
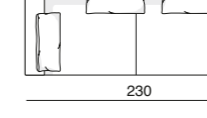
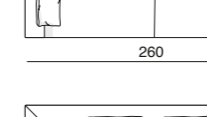
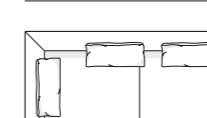
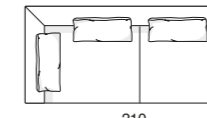
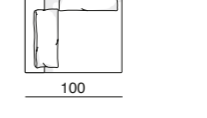
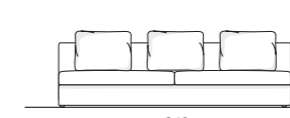
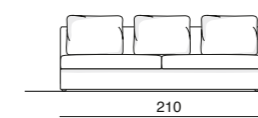
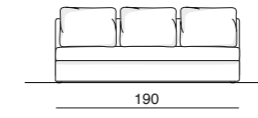
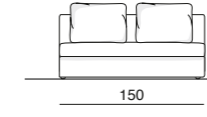
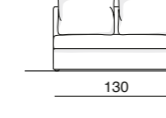
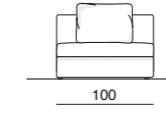
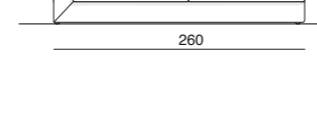
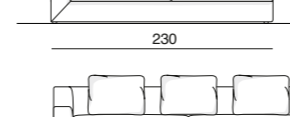
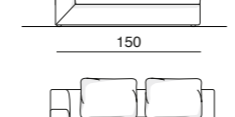
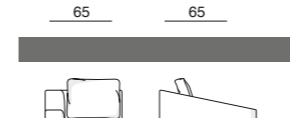
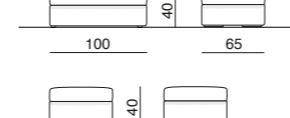
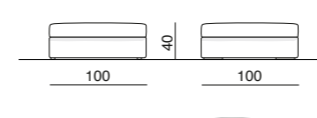
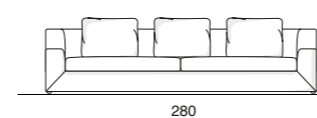
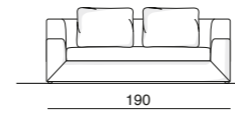
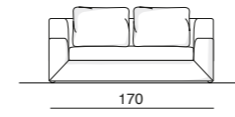
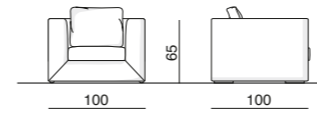
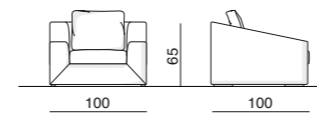

# MOVE

UN'ATMOSFERA COMODA E ACCOGLIENTE DOVE PADRONEGGIA PACE E TRANQUILLITÀ. FORMA LINEARE E SQUADRATA PER LA COMPOSIZIONE ANGOLARE DOVE APPOGGIANO CUSCINETTI DI VARIO TIPO PER ACCOGLIERE MEGLIO OGNI PARTE DEL CORPO. NEI COMPONENTI SI TROVANO VARIE SOLUZIONI PER SFRUTTARE NEL MIGLIOR MODO SPAZI VIVIBILI DI OGNI AMBIENTE.

IN A COMFORTABLE AND COSY ATMOSPHERE PEACE AND QUIET REIGNS. ITS SELF LINEAR AND SQUARED SHAPE IN THE ANGULAR COMPOSITION WHERE THE DIFFERENTING SUPPORT CUSHIONS WELCOME EVERY PART OF THE BODY.

Атмосфера комфорта и уюта, где царят мир и покой. Форма прямая или под углом, подушки разных размеров, создающие мягкую опору всему телу. Модульные конструкции позволят наиболее удачно использовать пространство любого помещения.



MOVE











## MOVE

L'EVOLUZIONE DEL DIVANO SI SOFFERMA MOLTO AL MOVIMENTO DELLO SCHIENALE. DALLA NOSTRA POSIZIONE IN ORIGINE SI POSSONO VEDERE LE VARIE TRASFORMAZIONI ALZANDO ENTRAMBE GLI SCHIENALI RIUSCENDO AD OTTENERE UNA PROFONDITÀ RIDOTTA PER PIACEVOLI CONVERSAZIONI. NEI DETTAGLI NOTIAMO L'ORIGINALITÀ DELLO SCHIENALE GIREVOLE, SI MUOVE SU OGNI SINGOLO PEZZO, POSSIAMO AVERE LA SEDUTA RIDOTTA DA UNA PARTE E LA SEDUTA DI RELAX DALLA PARTE OPPOSTA LO SI PUÒ ALZARE COMPLETAMENTE PER ACCOGLIERE LA FASCIA DELLE SPALLE DANDO COMFORT.

THE EVOLUTION OF THE SOFA EMPHASIZES EVERY MOVEMENT OF THE BACKREST. FROM OUR ORIGINAL POSITION YOU CAN SEE THE VARIOUS TRASFORMAZIONI BY RAISING BOTH BACKREST SUCCEEDING IN OBTAINING A REDUCED DEPTH FOR PLEASANT CONVERSATION. IN DETAIL WE SEE THE ORIGINALITY OF THE BACKREST STIVE, EACH MOVING PIECE, WITH WE HAVE REDUCED ON ONE SIDE AND THE RELAXATION ON THE OTHER SIDE WITH YOU CAN RAISE TO ACCOMODATE THE FULL RANGE OF THE SHOULDERS, LIVING MAXIMUM COMFORT.

Новые тенденции в эволюции дивана обычно мало затрагивают такой момент, как подвижность спинки. Мы думали об этом, создавая диван со смещающейся спинкой, которая позволяет уменьшить глубину сидения, делая его особенно удобным для приятного и непринуждённого общения. Ещё одна особенность спинки в том, что её части могут смещаться независимо друг от друга – одна часть дивана может оставаться в положении «релакс», то есть, с обычной глубиной, в то время как глубину второго сидячего места можно уменьшить.





# MOVE

LO SVILUPPO DEL DIVANO, PROSEGUE CON UN'ACCOGLIENTE CHAISE LONGUE STUDIATA SOPRATTUTTO PER GUARDARE LO SCHERMO STANDO DISTESI NELL'ASSOLUTA TRANQUILLITÀ, VIVENDO AL MEGLIO L'AMBIENTE. ANCHE PER MOVE POSSIAMO AVERE LA VERSIONE POLTRONA, DIVANI, VERSIONE CON CHAISE LONGUE E NELLE VERSIONI ANGOLARI. RIVESTIMENTO COMPLETAMENTE SFODERABILE E INTERCAMBIABILE.

THE DEVELOPMENT OF THE COUCH CONTINUES WITH A COMFORTABLE CHAISE LONGUE DESIGNED ESPECIALLY TO WATCH THE SCREEN LYING IN PEACE, LIVING IN THE BEST POSSIBLE ENVIRONMENT. MOVE ALSO HAS THE ARMCHAIR, SOFA, CHAISE LONGUE VERSION AND WITH ANGULAR ONES. THE COVERING IS COMPLETELY REMOVABLE AND INTERCHANGEABLE.

Модельный ряд серии Move продолжает уютный диван-шезлонг, разработанный специально для комфортного и спокойного отдыха перед голубым экраном. Как и другие модели, Move может выполняться в виде кресла, маленького или большого дивана, прямого, под углом или с шезлонгом. Все чехлы полностью съёмные и при желании могут меняться.

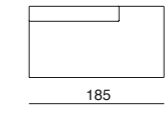
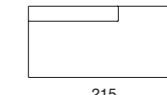
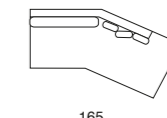
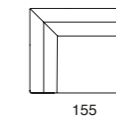
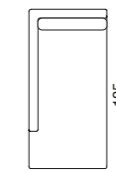
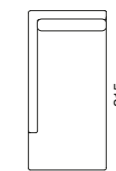
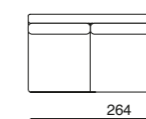
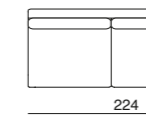
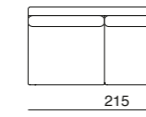
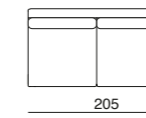
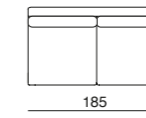
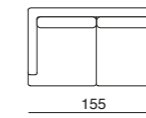
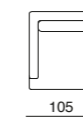
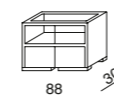
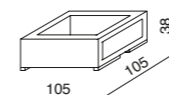
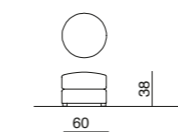
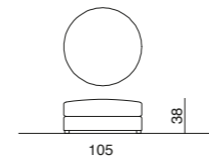
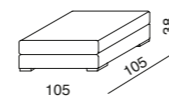
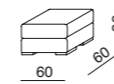
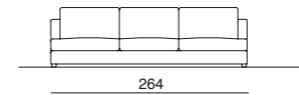
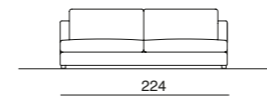
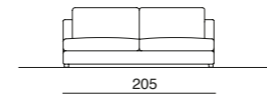
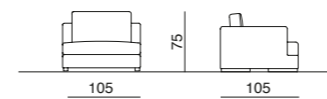

# ISLAND

UN NUOVO MODO DI VIVERE E CRESCERE IL SALOTTO, LA ZONA RELAX DIVENTA PROTAGONISTA NELLA CASA COME PERNO DOVE TUTTA LA VITA GIRA INTORNO. SVARIATE MISURE DI SEDUTA E SVARIATI ACCESSORI RENDONO QUESTO SALOTTO MOLTO FUNZIONALE AD OGNI ESIGENZA DI SPAZIO E DI ARREDO.

A NEW WAY TO LIVE AND BE PART OF THE LIVING ROOM, THE RELAXATION AREA IN THE HOUSE BECOMES THE PROTAGONIST WHERE LIFE REVOLVES AROUND IT. SEVERAL SITTING ARRANGEMENTS AND VARIOUS ACCESSORIES MAKE THIS ROOM VERY FUNCTIONAL FOR EVERY NEED OF SPALL AND FURNISHINGS.

Расширяющий пространство, ISLAND концентрирует в гостиной весь круговорот жизни, превращая зону отдыха в самое главное место в доме. Разнообразие размеров и аксессуаров позволяют ISLAND отлично вписаться в любое пространство и в любой интерьер.



ISLAND











## ISLAND

IL MODELLO ISLAND DA LA POSSIBILITÀ DI REALIZZARE COMPOSIZIONI DI VARIO GENERE E L'OPPORTUNITÀ DI AVERE INTORNO A SÈ LA LIBRERIA CONTENITORE.

THE MODEL ISLAND HAS THE POSSIBILITY OF VARIOUS KINDS OF COMPOSITIONS AND THE OPPORTUNITY TO HAVE A LIBRARY CONTAINERSURROUNDING IT.

Модель ISLAND дарит возможность создавать разнообразные композиции, которые по периметру могут быть дополнены книжными полками.







# ISLAND

ISLAND INFINE POSSIBILITÀ DI CREARE LA COMPOSIZIONE GIUSTA, CON ELEMENTI TERMINALI, ELEMENTI CENTRALI, CHAISE LONGUE E ANGOLI..

ISLAND FINALLY GIVES YOU THE ABILITY TO CREATE THE RIGHT COMPOSITION WITH END ELEMENTS TERMINALE,CENTRAL ELEMENTS, CHAISE LONGUE AND ANGLES.

Island дарит возможность создать идеальный интерьер, используя различные модули и варианты исполнения дивана.

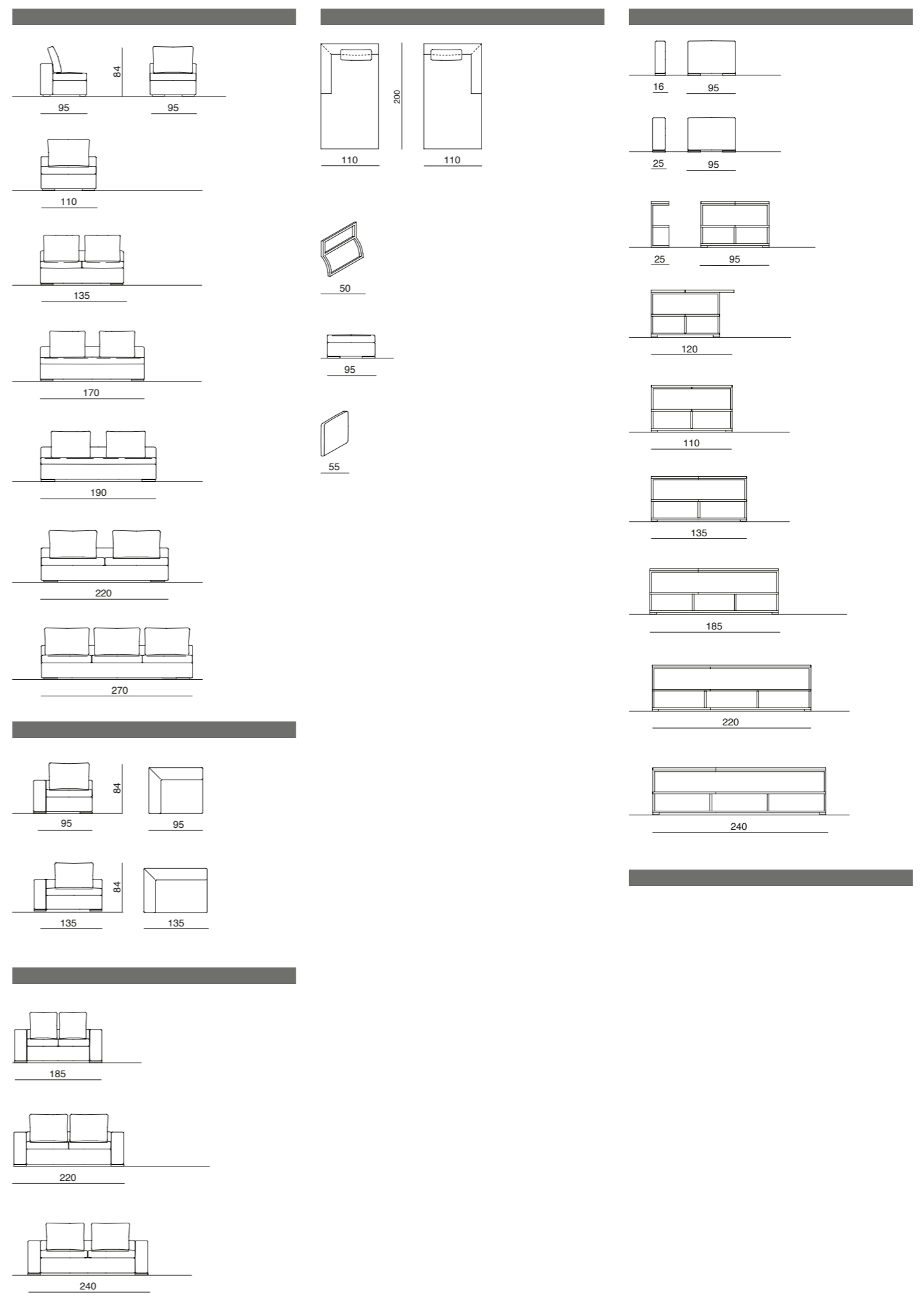

## TIP WING

FORMA LINEARE E PULITA DETERMINA LO STILE, CARATTERIZZATO DA UNA FORTE IDENTITÀ PROGETTUALE. UN'EVOLUZIONE NEL MONDO DELL'IMBOTTITO, RAFFINATO NEL DESIGN CURATO NEL PARTICOLOARE, NELLE FINIZIONI, CON ACCESSORI CHE PERSONALIZZANO LA PROPRIA COMPOSIZIONE.

LINEAR AND CLEAN DETERMINES THE STYLE CHARACTERIZED BY A STRONG IDENTITY DESIGN. AN EVOLUTION IN THE WORLD OF UPHOLSTERY, SUPERIOR ESPECIALLY IN FINISHES SOPHISTICATED DESIGN, WITH PERSONALIZE THEIR COMPOSITION.

Четкие, прямые линии определяют стиль, характеризующийся подчеркнутой индивидуальностью. Новый виток в развитии мягкой мебели, безупречный дизайн, продуманные детали, отделка, аксессуары, подчеркивающие индивидуальность каждой композиции.



TIP WING









## TIP WING

TIP WING NASCE DA UN'ATTENTA SELEZIONE DEI MATERIALI, LA CURA NELLA REALIZZAZIONE DI OGNI DETTAGLIO LA SCELTA DELLE FORME RIGOROSE E ALLO STESSO TEMPO CONFORTEVOLI. PENSATO IN MODO ELEGANTE, NELLA CLASSICA VERSIONE CON ENTRAMBE I BRACCIOLI IMBOTTITI.

TIP WING COMES FROM THE CAREFUL SELECTION OF MATERIALS, THE CARE IN MAKING EVERY DETAIL THE CHOICE OF A STRICT FORMS AND COMFORT. DESIGNED IN AN ELEGANT WAY, IN THE CLASSIC VERSION WITH BOTH ARMRESTS PADDED.

Создавая Tip wing, мы уделили особое внимание подбору материалов, разработке каждой детали и выбору формы – строгой и одновременно уютной. Элегантность классики в модели с двумя мягкими подлокотниками.









# TIPWING

I MATERIALI INNOVATIVI PER QUANTO RIGUARDA LA COSTRUZIONE DELLE STRUTTURE, LE IMBOTTITURE DEI DIVANI VENGONO ATTENTAMENTE SELEZIONATE PER SVILUPPARE AL MEGLIO IL COMFORT DESIDERATO.

LO POSSIAMO AVERE NELLA VERSIONE POLTRONA, DIVANI, COMPOSIZIONI ANGOLARI, COMPOSIZIONI CON CHAISELONGUE.

RIVESTIMENTI COMPLETAMENTE SFODERABILI E INTERCAMBIABILI.

THE INNOVATIVE MATERIALS CONCERNING THE CONSTRUCTION OF STRUCTURES, THE UPHOLSTERY OF SOFAS ARE CAREFULLY SELECTED TO BEST DEVELOP THE DESIRED COMFORT.

THIS VERSION IS AVAILABLE WE HAVE IN THE ARMCHAIR, THE SOFA, THE ANGULAR COMPOSITIONS WITH CHAISE LONGUE.

COVER IS COMPLETELY REMOVABLE AND INTERCHANGEABLE.

Иновационные материалы, использующиеся в каркасах, материалы наполнителей тщательно отобраны для создания максимального комфорта. Выполняется в виде кресла, маленького или большого дивана, прямого, под углом или с шезлонгом.

Все чехлы полностью съёмные и при желании могут меняться.

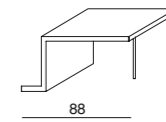
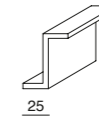
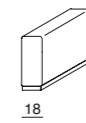
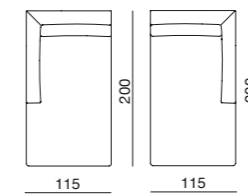
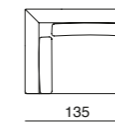
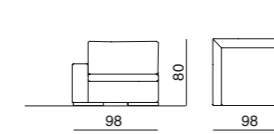
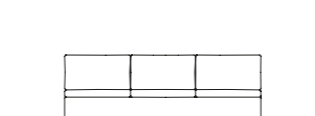
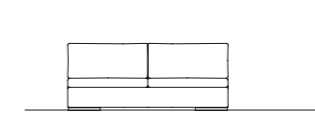
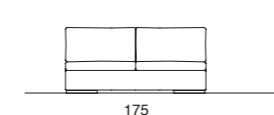
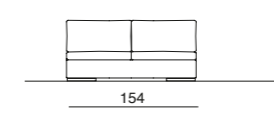
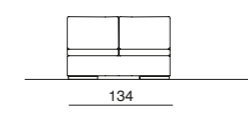
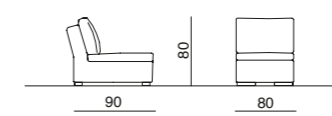
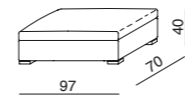
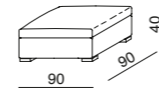
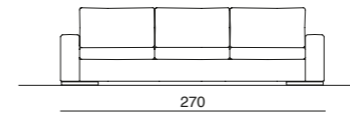
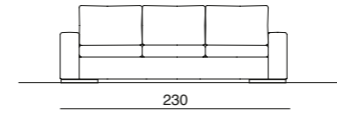
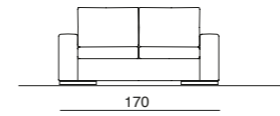

# RULING

RULING NASCE DA UN'ATTENTA RICERCA DI DESIGN E CONFORT MA SOPRATTUTTO STUDIATO PER FACILITARNE QUALSIASI TIPO DI AMBIENTAZIONE. E' REALIZZATO IN DIVERSE MISURE E COMPOSIZIONI.

RULING COMES FROM CAREFUL DESIGN AND COMFORT RESEARCH, BUT PARTICULARLY DESIGNED TO FACILITATE ANY TYPE OF ENVIRONMENT. IT'S MADE IN DIFFERENT SIZES AND COMPOSITIONS.

Ruling – это результат неустанного поиска решений для создания стильной и комфортной мебели.





# RULING







## RULING

LA PARTICOLARITÀ DI QUESTO MODELLO È DATA DA UN PIEDE IN ACCIAIO INOX, CHE SEGUE LA FORMA DEL BRACCIOLO. E' PROPOSTO IN VERSIONE CROMATA CON SCIVOLANTE PROTETTIVO IN FELTRO. QUESTO MODELLO HA LA SUA PANCHETTA CHE ACCOSTATA AL DIVANO CREA LA COMPOSIZIONE A CHAISE LONGUE.

THE PARTICULAR OF THIS MODEL IS GIVEN BY ITS STAINLESS STEEL FEET, WHICH FOLLOW THE SHAPE OF THE ARMREST. IT IS PROPOSED IN THE CHROMED VERSION WITH SLIDING PROTECTIVE FELT. THIS MODEL HAS A BENCH THAT CREATES THE COMPOSITION OF A CHAISE LONGUE.

Изюминка этой модели – в необычных стальных ножках, которые повторяют форму подлокотников. Хромированные ножки имеют войлочные накладки против скольжения. В комплекте с банкеткой эта модель может превращаться в диван с шезлонгом.





# RULING

IL PROGRAMMA RULING DA LA POSSIBILITÀ DI REALIZZARE POLTRONE, DIVANI COMPOSIZIONI ANGOLARI, COMPOSIZIONI CON PANCHETTA CHE SI TRASFORMA IN CHAISE LONGUE.

THE PROGRAMME RULING GIVES THE POSSIBILITY OF MAKING ARMCHAIRS, SOFAS, ANGULAR COMPOSITIONS, WITH A SMALL BENCH THAT TURNS, INTO A CHAISE LONGUE.

Модель Ruling может быть выполнена в виде кресла, углового дивана, композиции с банкеткой, трансформирующейся в шезлонг.

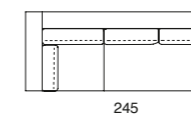
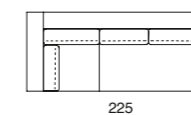
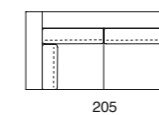
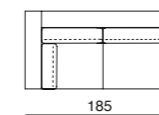
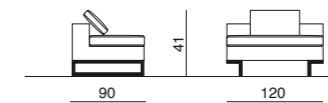
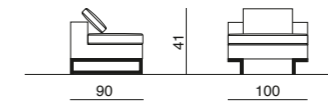
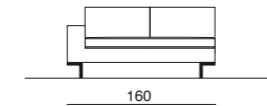
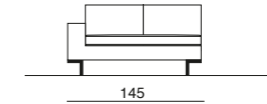
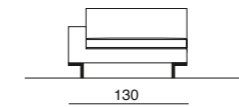
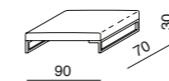
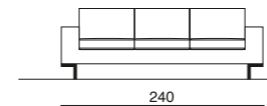
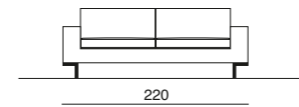
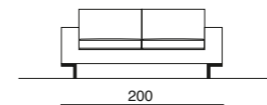
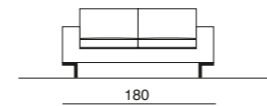
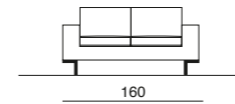
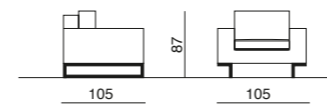

# SABOT

ATMOSFERE INCANTEVOLI IN CASE MOLTO ATTUALI DOVE ANCHE UN SEMPLICE IMBOTTITO HA LA CAPACITÀ DI AVERE VITA PROPRIA.  
SONO DIVANI FATTI PER SEDERSI, DISTENDERSI SOLO PER IL COMODO RELAX.

WONDERFUL ATMOSPHERES IN HOMES TODAY WHERE A VERY SIMPLE UPHOLSTERY HAS THE ABILITY TO HAVE IT'S OWN LIFE.  
SOFAS ARE MADE TO SIT ON TO LIE ON OR JUST TO BE COMFORTABLE.

Атмосфера уюта и обаяние индивидуальности в современном интерьере.  
Удобный диван, сев на который, сразу погружаешься в мир покоя и отдыха.



SABOT







## SABOT

L'AMBIENTE È SEMPRE UN GUSTO ESTETICO, QUINDI È POSSIBILE SCEGLIERE LA PROPRIA COMPOSIZIONE, IL PIEDE IN ACCIAIO OPPURE IN LEGNO FAGGIO IN VARIE COLORAZIONI.

THE ENVIRONMENT IS ALWAYS AN AESTHETIC TASTE, SO YOU CAN CHOOSE YOUR OWN COMPOSITION, FOOT STEEL FEET OR BEECH WOOD IN VARIOUS COLOURS.

Вы сможете создать модель именно для Вашего дома, подобрав нужную композицию, стальные или деревянные ножки, цвет их отделки.





# SABOT

LA STRUTTURA È REALIZZATA IN LEGNO MASSELLO, SEDUTA E SCHIENALE SONO SORRETTI DA CINGHIE ELASTICHE. IL MATERIALE DI IMBOTTITURA IN ESPANSO INDEFORMABILE ED ALTA RESISTENZA A QUOTE DIFFERENZIALI, GARANTISCE COMFORT CONSERVANDO NEL TEMPO LA FORMA ORIGINALE E LA STESSA SOLIDITÀ.

THE STRUCTURE IS MADE OF SOLID WOOD SEAT AND BACKREST SUPPORTED BY ELASTIC BELTS.

THE CUSHIONING MATERIAL IS MADE OF HIGH RESISTANCE DIFFERENTIATED NON DEFORMABLE FOAM ENSURING COMFORT IN TIME WHILE PRESERVING THE ORIGINAL SHAPE AND THE SAME SOLIDITY.

Каркас выполнен из массива дерева, опора спинки и сидения – из эластичных переплетённых ремней. Наполнитель из недеформирующегося пенополиуретана, устойчивого к различным нагрузкам, гарантирует комфорт и надолго сохраняет изначальную форму и упругость подушек.

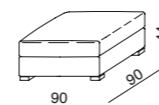
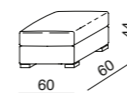
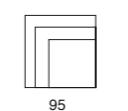
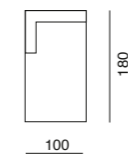
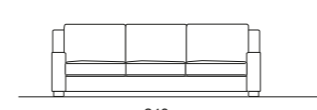
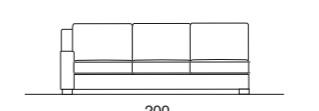
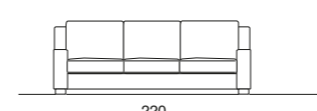
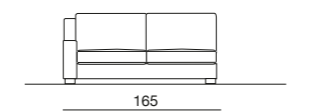
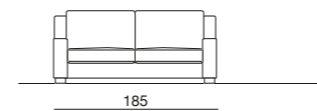
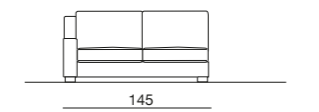
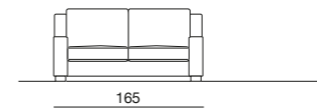
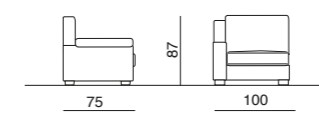
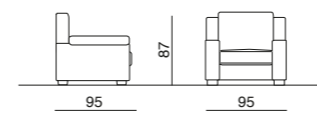

## POPPY NEW

LA SEMPLICITÀ USA MATERIALI NOTI E FORME CONOSCIUTE, MA CONSIDERA LA RICONOSCIBILITÀ DELLE TIPOLOGIE COME UNA RISORSA, PER QUESTO È NATO POPPY NEW.

NEW POPPY WAS BORN BY USING THE SIMPLICITY OF KNOWN FORSA MATERIALS YET RECOGNITING THE TYPOLOGIES AS A RE SOURCE.

Знакомые формы, известные материалы – модель Poppy new мы создали, взяв за источник элегантную простоту классики.



POPPY NEW





## POPPY NEW

PARTICOLARITÀ DI QUESTO MODELLO SONO IL GRAN NUMERO DI CUSCINI, UTILIZZATI PER RENDERLO ANCORA PIÙ COMODO, ACCOGLIENTE E DINAMICO. POPPY NASCE CON LA POSSIBILITÀ DI AVERE LA PROFONDITÀ CM. 110 OPPURE NELLA VERSIONE DA CM. 85.

WHAT MAKES UP THIS MODEL IS THE LARGE NUMBER OF CUSHIONS USED, MAKING IT EVEN MORE COMFORTABLE WELCOMING AND DYNAMIC. POPPY NEW WAS BORN WITH THE ABILITY TO HAVE THE DEPTH OF 110 CM. OR IN THE 85 CM VERSION.

Особенность этой модели - в большом количестве подушек, которые делают её ещё более комфортной, уютной и динамичной.





# POPPY NEW

LA STRUTTURA È REALIZZATA IN LEGNO MASSELLO, SEDUTA E SCHIENALI SONO SORRETTI DA CINGHIE ELASTICHE. IL MATERIALE DI IMBOTTITURA IN ESPANSO INDEFORMABILE AD ALTA RESISTENZA A QUOTE DIFFERENZIALI, GARANTISCE COMFORT CONSERVANDO NEL TEMPO LA FORMA ORIGINALE E LA STESSA SOLIDITÀ. POPPY È POLTRONA, DIVANI, COMPOSIZIONI ANGOLARI.

THE STRUCTURE IS MADE OF SOLID WOOD SEAT AND BACKREST SUPPORTED BY ELASTIC BELTS. THE CUSHION MATERIAL IN HIGH-STRENGTH DIFFERENTIATED NON DEFORMABLE FOAM IN ENSURES CONFORT IN TIME RETAINING THE ORIGINAL SHAPE AND THE SAME SOLIDITY. POPPY IS ARMCHAIRS, SOFA, ANGULAR COMPOSITIONS.

Наполнитель из недеформирующегося пенополиуретана, устойчивого к различным нагрузкам, гарантирует комфорт и надолго сохраняет изначальную форму и упругость подушек. Poppy new выполняется в виде диванов, кресел, угловых композиций.

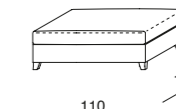
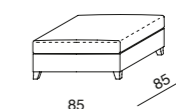
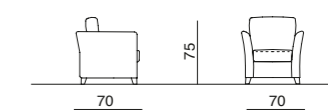
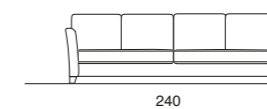
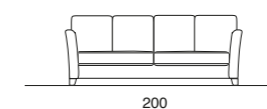
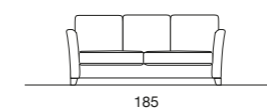
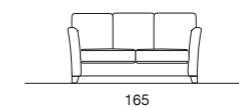
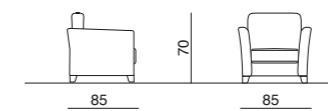
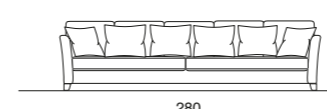
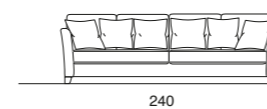
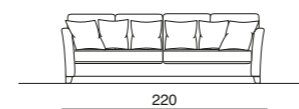
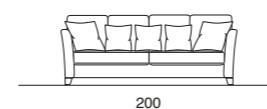
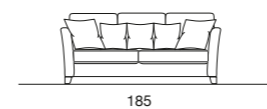
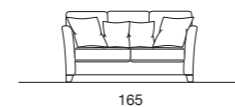
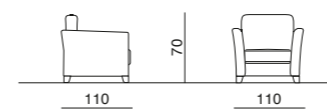

# MITO

MITO È UN PROGRAMMA COMPLETAMENTE COMPONIBILE STUDIATO PER SODDISFARE OGNI PICCOLA ESIGENZA.  
LA COSA INTERESSANTE SONO LE COMPOSIZIONI ANGOLARI, SI PARTE DA UNA MISURA ANGOLO FISSA PER OTTENERE TUTTE LE POSSIBILI EVOLUZIONI.

MITO IS AN ENTIRELY MODULAR DESIGN TO MEET EVERY LITTLE NEED.  
WHAT'S INTERESTING IS THE COMPOSITIONS CORNER, THE PARTICULARITY OF MITO IS IN THE UPPER CORNER WHICH HAS A SUPPORTING SHELF THAT IS INDISPENSABILE FOR A POWER POINT.

Серия модульной мебели, разработанной для того, чтобы идеально вписаться в любое пространство.  
Интересная деталь – фиксированные размеры углового модуля, что позволяет легко составлять все возможные угловые композиции.



MITO





## MITO

IL PARTICOLARE DI MITO È NELLA PARTE POSTERIORE DELL'ELEMENTO ANGOLO CON PIANO D'APPOGGIO MENSOLA, INDISPENSABILE ANCHE COME PUNTO LUCE. QUESTO ELEMENTO UNICO NELLA SUA VERSIONE È DISPONIBILE NELLE COLORAZIONI A CATALOGO.

WHERE YOU CAN OBTAIN ALL POSSIBLE TRASFORMATIONS STAILTING FROM A FINED CORNEL POINT.

Изюминка модели Mito – задняя часть углового модуля с возможностью установки полки, которую очень удобно использовать как подставку для светильника. В каталоге представлены различные варианты отделки дерева.



# MITO

LA STRUTTURA È REALIZZATA IN LEGNO MASSELLO, SEDUTA E SCHIENALI SONO SORRETTI DA CINGHIE ELASTICHE. IL MATERIALE DI IMBOTTITURA IN ESPANSO INDEFORMABILE AD ALTA RESISTENZA A QUOTE DIFFERENZIALI, GARANTISCE COMFORT CONSERVANDO NEL TEMPO LA FORMA ORIGINALE E LA STESSA SOLIDITÀ. MITO È POLTRONA, DIVANI, COMPOSIZIONI ANGOLARI.

THE STRUCTURE IS MADE OF A SOLID WOOD SEAT AND BACKREST SUPPORTED BY ELASTIC BELTS. THE CUSHION MATERIAL IS IN HIGH-STRENGTH DIFFERENTIATED NON DEFORMABLE FOAM, ENSURING COMFORT IN TIME AND RETAINING THE ORIGINAL SHAPE AND THE SAME SOLIDITY. MITO IS ARMCHAIRS, SOFA, ANGULAR COMPOSITIONS.

Каркас выполнен из массива дерева, опора спинки и сидения – из эластичных переплетённых ремней. Наполнитель из недеформирующегося пенополиуретана, устойчивого к различным нагрузкам, гарантирует комфорт и надолго сохраняет изначальную форму и упругость подушек. Mito выполняется в виде диванов, кресел, угловых композиций.

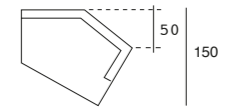
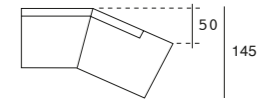
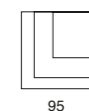
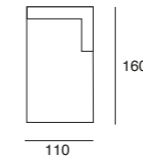
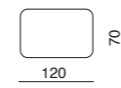
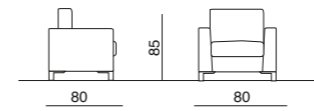
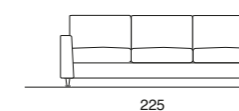
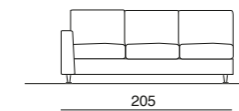
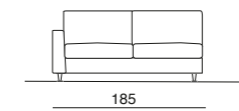
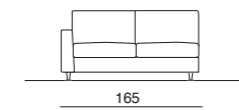
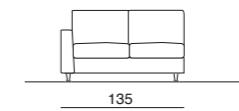
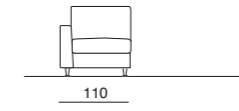
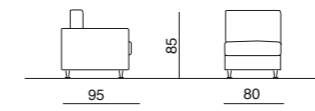
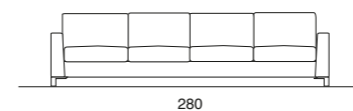
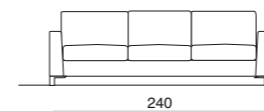
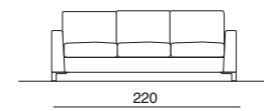
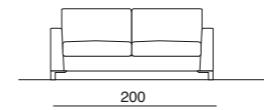
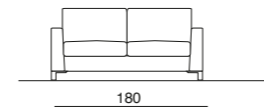
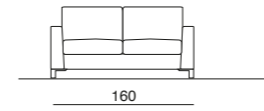

QUITE  
THEA  
SNAIL  
GOGO  
BADOS  
MALINDI  
GIN  
GIN ONE  
JEK  
STILL  
SER  
OPIE  
HOLLY

DALLE STORICHE POLTRONE, A QUELLE PIÙ RICERCATE, SI È CREATA UNA GAMMA DI ACCESSORI CHE COMPLETANO LO STILE DI OGNI ANGOLO CONVERSAZIONE PER FARLO UNICO NEL SUO GENERE.

DATING BACK FROM THE HISTORICAL ARMCHAIRS SEATS, TO THOSE MORE SOUGHT AFTER, A RANGE OF ACCESSORIES, HAS BEEN CREATED THAT COMPLEMENTS THE STYLE OF EACH CONVERSATION CORNER MAKING IT UNIQUE.

От классики до уникальных моделей – мы создали ряд аксессуаров для зоны отдыха, придающих ей завершенность и индивидуальность.



QUITE





## QUITE

LINEE ESSENZIALI RICCHEZZA DI PARTICOLARI, LAVORAZIONE ACCURATE E VARIE TIPOLOGIE DI MATERIALI RENDONO QUESTO OGGETTO DI RAFFINATA BELLEZZA. STRUTTURA COMPLETAMENTE IN METALLO CROMATO CUSCINO SEDUTA E SCHIENALE IN POLIURETANO ESPANSO DIFFERENZIATO.

ESSENTIAL LINES AND WEALTH OF DETAIL, CAREFUL PROCESSING AND VARIOUS TYPOLOGIES OF MATERIALS MAKE THIS AN OBJECT OF EXQUISITE BEAUTY. FULL METAL PLATED SEAT AND BACKREST CUSHION IN DIFFERENTIATED POLYURETHANE FOAM.

Чёткость и лёгкость линий, отличное качество, разнообразие материалов делают эту модель образчиком безупречной элегантности. Структура из хромированной стали, подушки сидения и спинки из многослойного пенополиуретана.

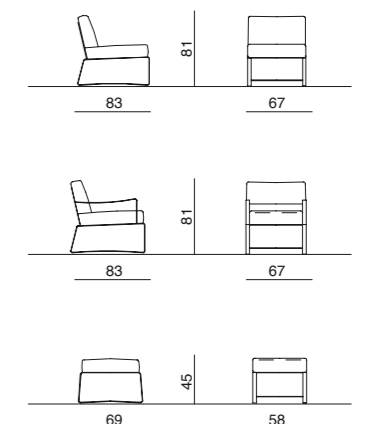





THEA



## THEA

E' LA POLTRONA CARATTERIZZATA DALL'ESTREMO RIGORE DEL DESIGN.  
COSTRUITA CON STRUTTURA IN LEGNO IMBOTTITURA IN ESPANSO INDEFORMABILE.  
CUSCINO SEDUTA IN ESPANSO INDEFORMABILE DIFFERENZIATO.  
RIVESTIMENTO COMPLETAMENTE SFODERABILE, BASAMENTO IN METALLO CROMATO  
GIREVOLE.

THEA I SAN ARMCHAIR CHARACTERIZED WITH EXTREME DESIGN RIGOUR.  
CONSTRUCTED WITH WOODEN FRAME PADDED WITH NON DEFORMABLE FOAM CUSHION  
SEAT. SEAT CUSHION FOAM DEFORMABLE DIFFERENTIATED.  
COMPLETELY REMOVABLE, STEEL SWIVEL BASE.

Это кресло отличается особенно строгим дизайном.  
Каркас выполнен из дерева, вращающееся основание - из стали, наполнитель –  
недеформирующийся пенополиуретан.  
Подушка сидения из недеформирующегося многослойного пенополиуретана.  
Обивка полностью съёмная.

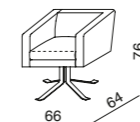



SNAIL



## SNAIL

ESSENZIALITÀ ELEGANZA ASSOLUTA, METICOLOSITÀ NELL' ESECUZIONE DI OGNI PARTICOLARE.

SI VALORIZZA AL MEGLIO LA STRUTTURA IN LEGNO MASSELLO TINTO NEI COLORI DELLA COLLEZIONE. CUSCINO SEDUTA IN POLIURETANO ESPANSO INDEFORMABILE AD ALTA RESILIENZA. CUSCINO SCHIENALE IN PIUMA D'OCA CANALIZZATA.

ABSOLUTE ESSENTIAL ELEGANCE, METICULOUS EXECUTION OF EVERY DETAIL. THE SOLID WOOD STRUCTURE, PAINTED IN COLOURS OF THE COLLECTION SETS IT OFF. SEAT CUSHION IN UNDEFORMABLE HIGH RESILIENCE POLYURETHANE FOAM. BACKREST CUSHIONS IN GOOSE DOWN FEATHER CHanneled.

Идеал элегантности, внимание к каждой детали.  
Лейтмотив – каркас из массива дерева (различные варианты отделки из коллекции).  
Подушка сидения из прочного недеформирующегося пенополиуретана.  
Наполнитель спинки – гусиное перо.

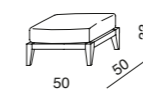
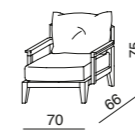



GOGO

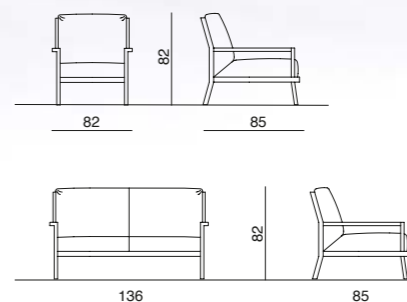





# BADOS

## BADOS

STRUTTURA IN LEGNO MASSELLO, RIVESTITA IN TESSUTO PROTETTIVO ACCOPPIATO, CUSCINO SEDUTA IN POLIURETANO ESPANSO DIFFERENZIATO. RIVESTIMENTO COMPLETAMENTE SFODERABILE.

SOLID WOOD FRAME, COVERED IN PROTECTIVE FABRIC, SEAT CUSHION IN DIFFERENTIATED POLYURETHANE FOAM. COMPLETELY REMOVABLE COVER.

Каркас из массива, двухслойная обивка. Подушка сидения из многослойного пенополиуретана. Обивка полностью съёмная.

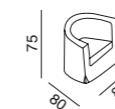



# MALINDI



## MALINDI

IL PARTICOLARE DELLA STRUTTURA IN GIUNCO INTRECCIATO, COME TELA LA RENDE UNICA NEL SUO GENERE.  
STRUTTURA IN LEGNO MASSELLO TINTO NEI COLORI DELLA COLLEZIONE, CUSCINO SEDUTA IN POLIURETANO ESPANSO INDEFORMABILE DIFFERENZIATO, CUSCINO SCHIENALE IN PIUMA D'OCA CANALIZZATA.

THE PARTICULAR STRUCTURE OF WOVEN RUSH, LIKE CANVAS, MAKES IT UNIQUE.  
STRUCTURE IN SOLID WOOD PAINTED IN THE COLORS OF THE COLLECTION, NON DEFORMABLE DIFFERENTIATED POLYURETHANE FOAM SEAT CUSHION GOOSE DOWN BACKREST CHANNELED.

Особенность этой модели – каркас с тростниковым плетением.  
Коллекция разнообразных отделок деревянных деталей, подушка сидения из многослойного недеформирующегося пенополиуретана, наполнитель спинки – гусиное перо.

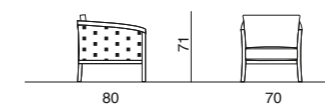



# GIN GIN ONE JEK

## GIN - GIN ONE - JEK

SERIE DI TAVOLINI CHE EVOCANO LA CONVERSAZIONE.  
CHI A LATO DIVANO, CHI DAVANTI AL DIVANO.

STILL A SERIES OF COFFEE TABLES WHICH EVOKE CONVERSATIONS.  
WHO BESIDE THE SOFA, WHO IS IN FRONT OF BEFORE THE SOFA.

Возвращение к традиции - серия приставных столиков для уголка отдыха. Могут располагаться как сбоку, так и перед диваном.

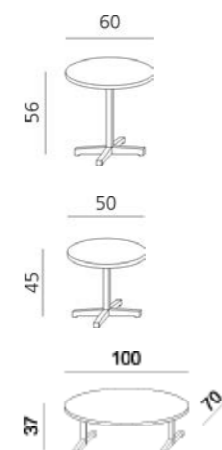



# STILL

## STILL

SERIE DI TAVOLINI CHE EVOCANO LA CONVERSAZIONE.  
CHI A LATO DIVANO, CHI DAVANTI AL DIVANO.

STILL A SERIES OF COFFEE TABLES WHICH EVOKE CONVERSATIONS.  
WHO BESIDE THE SOFA, WHO IS IN FRONT OF BEFORE THE SOFA.

Возвращение к традиции - серия приставных столиков для уголка отдыха.  
Могут располагаться как сбоку, так и перед диваном.

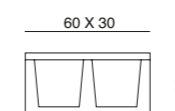
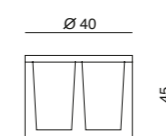
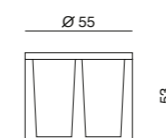
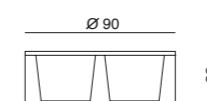



SER

SER

SISTEMA DI COMPLEMENTI D'ARREDO PER LA ZONA SALOTTO  
 SER ALTO DI SERVIZIO AI DIVANI  
 SER QUADRO AL CENTRO DELLE CONVERSAZIONI  
 SER POUFF PER COMPLETARE SER QUADRO CON CUSCINO PER POGGIAPIEDI.

SYSTEM FURNISHINGS LOUNGE AREA  
 SER GIVES HIGH SERVICE TO SOFAS  
 SER FRAMEWORK AT THE CENTER OF CONVERSATIONS  
 SER SER OTTOMAN TO COMPLETE THE FRAMEWORK WITH CUSHION FOOTREST

Коллекция аксессуаров для гостиной.  
 Ser alto – приставной столик к дивану.  
 Ser quadro – квадратный журнальный столик.  
 Ser pouff – пуф для ног с подушкой.

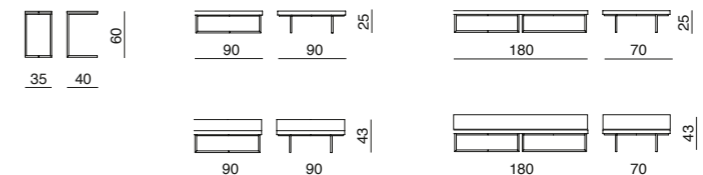



# OPIE

## OPIE

NATA PER L'ESIGENZA DI ACCOMPAGNARE LE CONVERSAZIONI E SCALDARE L'AMBIENTE CON LUCE SOFFUSA, IMPREZIOSITA CON DIFFUSORE CHE SI ACCOMPAGNA AL DETTAGLIO DEL DIVANO.

BORN FOR THE NEED TO ACCOMPANY THE CONVERSATION AND WARM THE ENVIRONMENT WITH DIM LIGHTING, ADORNED WITH A LAMPSHADE THAT THE DETAIL OF THE COUCH.

Мягкий приглушённый свет, дарящий тепло и уют во время вечернего отдыха. Ткань абажура можно подобрать к обивке дивана.

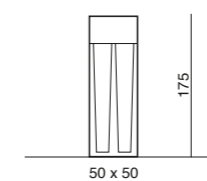



# HOLLY

## HOLLY

NATA PER L'ESIGENZA DI ACCOMPAGNARE LE CONVERSAZIONI E SCALDARE L'AMBIENTE CON LUCE SOFFUSA, IMPREZIOSITA CON DIFFUSORE CHE SI ACCOMPAGNA AL DETTAGLIO DEL DIVANO.

BORN FOR THE NEED TO ACCOMPANY THE CONVERSATION AND WARM THE ENVIRONMENT WITH DIM LIGHTING, ADORNED WITH A LAMPSHADE THAT THE DETAIL OF THE COUCH.

Мягкий приглушённый свет, дарящий тепло и уют во время вечернего отдыха. Ткань абажура можно подобрать к обивке дивана.

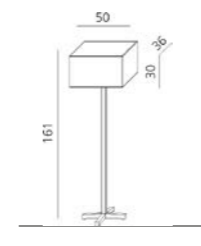

PRINCE

FACILE 1

FACILE 2

MIDI'

PETIT

DAL GUSTO DEL DESIGN SI PASSA AI DIVANI CONSIDERATI NOBILI PER SEMPRE, SONO LINEE ARROTONDATE PER UN GUSTO INTRAMONTABILE.

TASTE OF THE DESIGN IS PASSED TO THE FOREVER SOFAS CONSIDERED NOBLE, ARE SOFT AND ROUNDED LINES FOR A TIMELESS STYLE.

От изысков современности до благородной классики – непреходящая свежесть безупречной элегантности.





PRINCE



## PRINCE

LA NOSTRA ANTICA CULTURA ARTIGIANALE CON LAVORAZIONE DI FONDO CLASSICHEGGIANTE MISCHIATA CON TENDENZE DI DESIGN FORMA UN PERFETTO EQUILIBRIO. STRUTTURA RICOPERTA IN PELLE NON SFODERABILE IN ABBINAMENTO A TESSUTI TECNICI DANNO ACCOGLIENZA QUANDO SI VIVE IL DIVANO.

OUR ANCIENT CRAFT CULTURE WITH BASIC WORK MIXED WITH CLASSICAL DESIGN TRENDS FORMS A PERFECT BALANCE. NON-REMOVABLE LEATHER-COVERED STRUCTURE IN COMBINATION WITH TECHNICAL FABRICS WELCOMES YOU WHEN YOU LIVE ON THE COUCH.

Древние традиции нашей ремесленной культуры отлично гармонируют с современными тенденциями дизайна. Обивка из несъемной кожи с подкладкой из ткани делают диван очень долговечным.

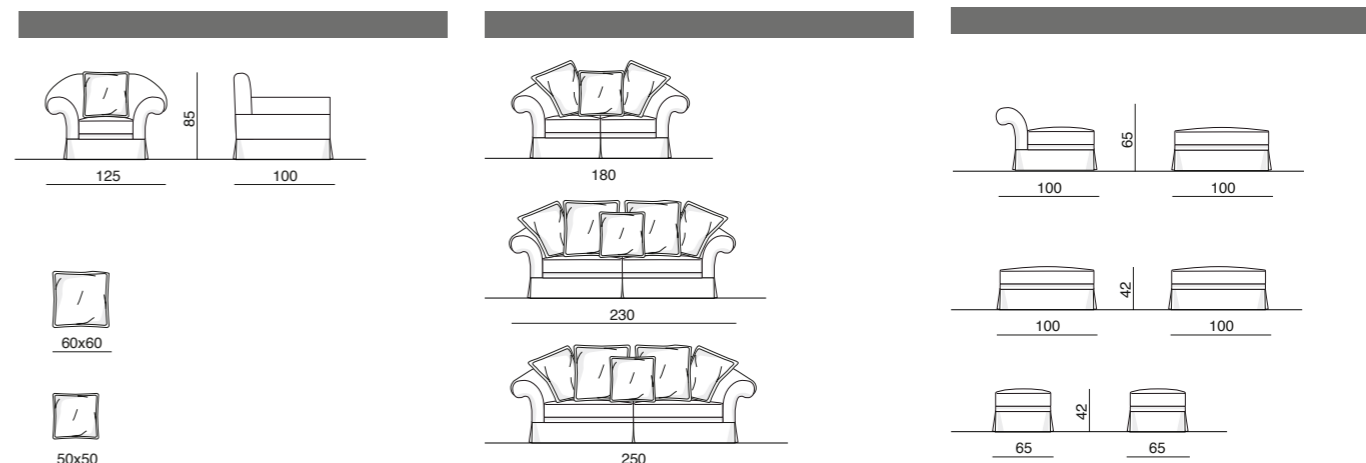



# FACILE 1

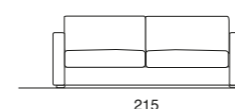
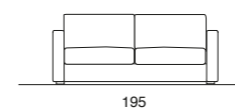
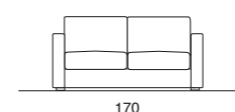
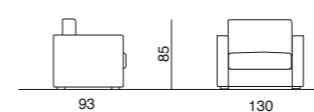

## FACILE 1

OTTIMO COMPROMESSO FRA GIORNO E NOTTE, VIVIBILE E TRASFORMABILE MEGLIO COME LETTO, L'UNICO ELEMENTO VINCOLANTE NELL'AMBIENTE SONO LE MISURE. FACILE 1 SI PRESENTA CON UN BRACCIOLO QUADRATO PER AMBIENTI MODERNI. COMODO E VERSATILE DA PREPARARE PER LA NOTTE.

GOOD COMPROMISE BETWEEN DAY AND NIGHT, LIVABLE AND CONVERTIBLE AS A BED, SPALE BEING THE ONLY RESTRAINING ELEMENT IN THE ENVIRONMENT. FACILE 1 SHOWS A ARMREST FOR MODERN SQUARED ENVIRONMENTS. CONVENIENT AND VERSATILE TO PREPARE FOR THE NIGHT.

Отличная модель для дня и ночи – компактный диван, который одним простым движением можно превратить в кровать. Диван Facile 1 с прямоугольными подлокотниками для современного интерьера. Удобная и универсальная модель.



# FACILE 2

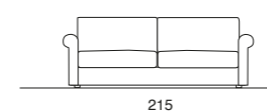
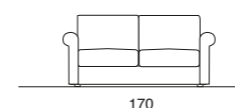
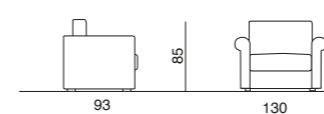

## FACILE 2

OTTIMO COMPROMESSO FRA GIORNO E NOTTE, VIVIBILE E TRASFORMABILE MEGLIO COME LETTO, L'UNICO ELEMENTO VINCOLANTE NELL'AMBIENTE SONO LE MISURE. FACILE 2 SI PRESENTA CON UN BRACCIOLO A RICCIOLIO PER AMBIENTI CLASSICI. COMODO E VERSATILE DA PREPARARE PER LA NOTTE.

GOOD COMPROMISE BETWEEN DAY AND NIGHT, LIVABLE AND CONVERTIBLE AS A BED, SPALE BEING THE ONLY RESTRAINING ELEMENT IN THE ENVIRONMENT. FACILE 2 SHOWS A CURLED ARM FOR CLASSIC ENVIRONMENTS. COMFORTABLE AND VERSATILE TO PREPARE FOR THE NIGHT.

Отличная модель для дня и ночи – компактный диван, который одним простым движением можно превратить в кровать. Диван Facile 2 с закруглёнными подлокотниками для классических интерьеров. Удобная и универсальная модель.



# MIDI'



## MIDI'

NELL'USO QUOTIDIANO DELL'AMBIENTE È NATA L'ESIGENZA DI IMPREZIOSIRE IL TAVOLO DA PRANZO CON SEDIE E POLTRONCINE. PIACEVOLI PER PASSARE UNA SERATA TRA AMICI. SI PRESENTANO BENISSIMO IN AMBIENTI CLASSICI E MODERNI.

IN EVERYDAY ENVIRONMENT MIDI' HAS CREATED THE NEED TO EMBELLISH THE DINING TABLE WITH CHAIRS AND ARMCHAIRS. PLEASANT TO SPEND AN EVENING WITH FRIENDS. THEY FIT WELL INTO CLASSICAL AND MODERN ENVIRONMENT.

Стулья и кресла для повседневного использования за обеденным столом – утром, днём и вечером в кругу друзей. Отлично подходят как для современных, так и для классических интерьеров.

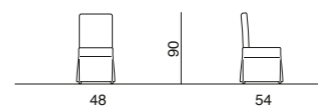
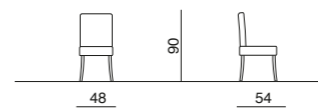



# PETIT



## PETIT

NELL'USO QUOTIDIANO DELL'AMBIENTE È NATA L'ESIGENZA DI IMPREZIOSIRE IL TAVOLO DA PRANZO CON SEDIE E POLTRONCINE. PIACEVOLI PER PASSARE UNA SERATA TRA AMICI. SI PRESENTANO BENISSIMO IN AMBIENTI CLASSICI E MODERNI.

IN THE EVERYDAY ENVIRONMENT PETIT HAS CREATED THE NEED TO EMBELLISH THE DINING TABLE WITH CHAIRS AND ARMCHAIRS. PLEASANT TO SPEND AN EVENING WITH FRIENDS. THEY FIT WELL INTO THE CLASSICAL AND MODERN ENVIRONMENT.

Стулья и кресла для повседневного использования за обеденным столом – утром, днём и вечером в кругу друзей. Отлично подходят как для современных, так и для классических интерьеров.

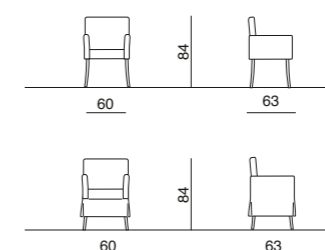

# FINITURE

## FINISHINGS

### METALLI METALS



ACCIAIO CROMATO  
LUCIDO



ORO LUCIDO



METALLO  
SPAZZOLATO OPACO



METALLO  
BRONZATO

### LACCATI LAQUERED



ANTRACITE

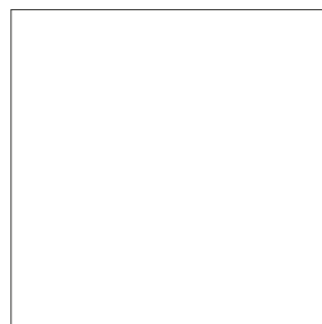

BIANCO



DESERTO

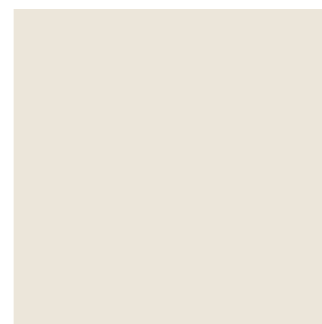

BEIGE

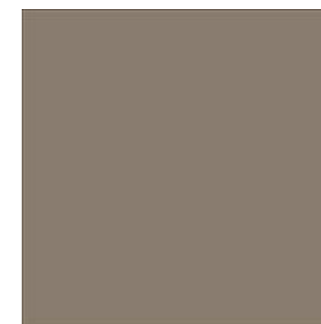

GRIGIO FUMO



GRIGIO ACCIAIO



CAFFE'



MATTONE

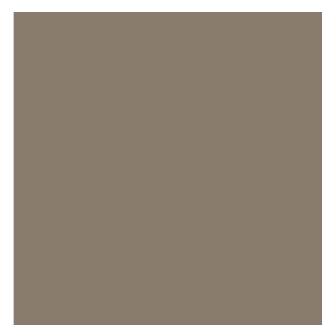

TORTORA



NERO

### LEGNI WOODS



ROVERE TINTO  
WENGE'

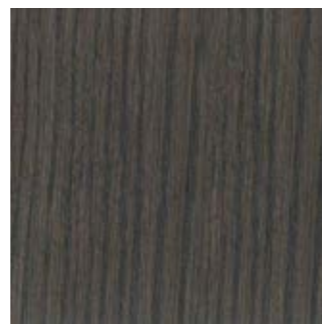

ROVERE TINTO  
GRIGIO

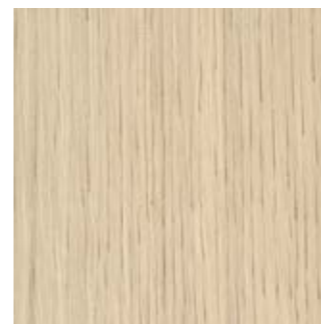

ROVERE SBIANCATO

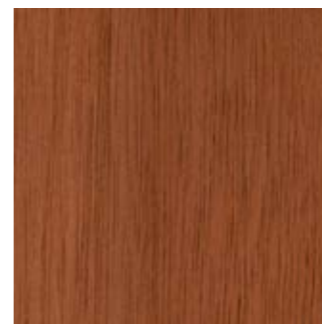

NOCE CANALETTO

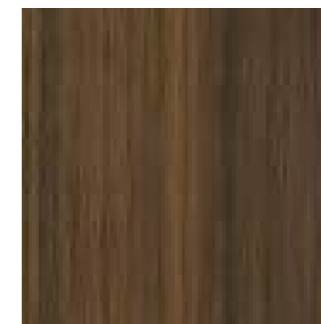

NOCE

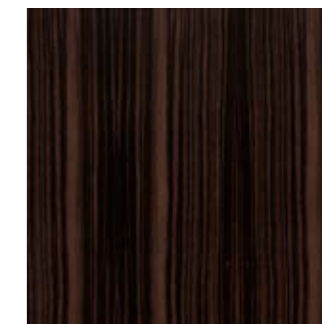

EBANO

LE TONALITÀ DEI COLORI E DEI MATERIALI  
SU CARTA HA UN VALORE INDICATIVO.

THE COLOURS AND MATERIALS SHADES  
REPRODUCED ON PAPER IS AN INDICATION.

ОТТЕНКИ ЦВЕТА ТКАНЕЙ В ПЕЧАТНОМ  
КАТАЛОГЕ МОГУТ НЕМНОГО  
ОТЛИЧАТЬСЯ ОТ РЕАЛЬНЫХ

---

STUDIO PROGETTAZIONE: **SORMANI**

ART DIRECTION: BELLAVISTA & PICCINI ARCHITETTI

PROGETTO GRAFICO: ARNALDO DALLA POZZA

---

**sormani** |

**SORMANI**

UFFICI E SHOW ROOM:  
VIA EDISON, 33  
20036 MEDA (MI)  
TELEFONO 036270064  
FAX 0362338681  
[WWW.SORMANIMBOTTI.IT](http://WWW.SORMANIMBOTTI.IT)  
[INFO@SORMANIMBOTTI.IT](mailto:INFO@SORMANIMBOTTI.IT)



